

Luminex

Operation Manual | RUO

ARIES[®] M1 System

Model: ARIES M6V1

ARIES Software v1.0

For Research Use Only. Not for use in diagnostic procedures.



© 2016 - 2021 Luminex Corporation. All rights reserved. No part of this publication may be reproduced, transmitted, transcribed, or translated into any language or computer language, in any form or by any means without prior express, written consent of Luminex Corporation.



Luminex Corporation

12212 Technology Blvd.
Austin, TX 78727
U.S.A.

Technical Support

Telephone: 512-381-4397
North America Toll Free: 1-877-785-2323
International Toll Free: + 800-2939-4959
Email: support@luminexcorp.com
www.luminexcorp.com

ARIES® M1 System Operation Manual

Model: ARIES M6V1
ARIES Software v1.0

PN 89-00002-00-538 Rev E
April 2021



Luminex B.V.
Het Zuiderkruis 1
5215 MV 's-Hertogenbosch
The Netherlands



Luminex Corporation (Luminex) reserves the right to modify its products and services at any time. This guide is subject to change without notice. Although prepared to ensure accuracy, Luminex assumes no liability for errors or omissions, or for any damages resulting from the application or use of this information.

Luminex and ARIES are trademarks of Luminex Corporation, registered in the U.S. and other countries.

All other trademarks, including Microsoft® Windows®, Life Technologies™, Wi-Fi®, and Berkshire™ Durx™ are trademarks of their respective companies.

This product, or use thereof, is covered, in whole or in part, or made by processes covered by one or more patents: www.luminexcorp.com/patents.

END USER TERMS AND CONDITIONS

These End User Terms and Conditions supersede the Standard Terms and Conditions of Use for Reagent Products, Standard Terms and Conditions of Use for Assay Products and Standard Terms and Conditions of Use for Instrument Products that may be included in the package inserts or manuals accompanying the Luminex products. By opening the packaging containing this assay, kit, cartridge or cassette (“Assay”), beads, sheath fluid or other reagents or accessories (“Reagents”) or Luminex instrument (“Instrument”), as applicable (Assays, Reagents and Instruments are collectively referenced as “Product(s)” herein) or by using such Product in any manner, you (the “End User” or “you”) are consenting and agreeing to be bound by the following terms and conditions. You are also agreeing that the following terms and conditions constitute a legally valid and binding contract that is enforceable against you. If you do not agree to all of the terms and conditions set forth below, you must promptly return the Product prior to using it in any manner.

- 1. Product Use and Restrictions** — End User agrees that (i) Luminex’s Products are intended for laboratory research and evaluation purposes only and End User will not use the Products for any diagnostic use and/or commercial applications or purposes, including without limitation performance of testing services, unless expressly agreed to in writing by Luminex; (ii) the Instruments are sold and licensed only for use with Reagents or Assays authorized by Luminex; (iii) the Reagents and Assays are sold and licensed only for use with Instruments; (iv) in order for End User to obtain the right under Luminex’s patents to use the Instrument, End User must purchase and use the Reagents or Assays on such Instrument; (v) End User will use the Reagents and Assays only once on a single use basis in order to maintain the quality of such Products and will not reuse such Products under any circumstance; (vi) for quality control purposes, End User will not use the Instruments with any beads, reagents or assays other than those authorized by Luminex; (vii) unless otherwise indicated in Product labeling, instructions or other Product documentation, the Products have not received approval from the federal Food and Drug Administration or other federal, state, or local regulatory agencies and have not been tested by Luminex for safety or efficacy in food, drug, medical device, cosmetic, commercial or any other use; (viii) End User will properly test and use any Products purchased from Luminex in accordance with the practices of a reasonable person who is an expert in the field and in strict compliance with all applicable laws, regulations, judicial orders and injunctions, now and hereinafter enacted; (ix) End User has the responsibility and hereby expressly assumes the risk to verify the hazards and to conduct any further research necessary to learn the hazards involved in using the Products; (x) End User also has the duty and sole responsibility to warn End User’s customers, employees, agents, assigns, officers, successors, and any auxiliary or third party personnel (such as freight handlers, etc.) of any and all risks involved in using or handling the Products; (xi) to comply with Product labeling and instructions, if any, furnished by Luminex relating to the use of the Products and not misuse the Products in any manner; (xii) End User will not reverse engineer, decompile, disassemble or modify the Products or create derivative works of the Software; (xiii) End User will not market, distribute, resell, rent, lease, loan or export the Products for any purpose; (xiv) Software licenses are not transferable; and (xv) End User will have no right to use any trademarks owned by or licensed to Luminex without the express written permission of Luminex.
- 2. End User’s Release and Indemnity** — End User agrees to release, discharge, disclaim, and renounce any and all claims, demands, actions, causes of action, and/or suits in law or equity, now existing or hereafter arising, whether known or unknown, against Luminex, including its subsidiaries and affiliates, and their respective officers, directors, employees, agents, successors, and assigns (collectively the “Released Parties”) with respect to the use of the Products or any deliverables provided with services. End User agrees to indemnify and hold harmless the Released Parties from and against any suits, losses, claims, demands, liabilities, costs, damages, actions, causes of action, and expenses (including without limitation attorney, accounting, expert witness, and consulting fees and court costs) that the Released Parties may sustain or incur arising from any claim against Luminex based upon negligence, breach of warranty, strict liability in tort, contract, or any other theory of law or equity arising out of, directly or indirectly, (i) the use of the Products or deliverables provided with ser-

vices, (ii) End User's or its agents', employees', representatives' or contractors' negligence or willful misconduct or failure to perform its obligations contained herein, (iii) Product modifications Luminex did not make or approve in writing, and (iv) End User's failure to acquire any additional third party rights. End User will notify Luminex in writing within fifteen (15) days of End User's becoming aware of any accident or incident involving the Products or deliverables provided with services which results in personal injury or damage to property, and End User will fully cooperate with Luminex in the investigation and determination of the cause of such accident and will make available to Luminex all statements, reports, recordings, and tests made by End User or made available to End User by others. The furnishing of such information to Luminex and any investigation by Luminex of such information or incident report will not in any way constitute any assumption of any liability for such accident or incident by Luminex.

3. **Intellectual Property** – Luminex does not warrant that the use or sale of the Products delivered hereunder will not infringe the claims of any United States or other patents covering the Product itself or the use thereof in combination with other products or in the operation of any process. End User acknowledges and agrees that (i) all intellectual property rights relating to or residing in Products and services or any portion thereof, as between Luminex and End User, are solely and exclusively owned by Luminex and (ii) End User receives no rights or licenses to Luminex intellectual property rights by virtue of End User's purchase of the Products and/or services other than expressly set forth herein.

For translations of this document, see <https://www.luminexcorp.com>.

89-30000-00-186 Rev H

End-User License Agreement (EULA) for Luminex® Software

This Luminex End-User License Agreement (“EULA”) is a legal agreement between you (either an individual or a single entity, also referred herein as “you”) the end-user and Luminex Corporation and its affiliates (collectively, “Luminex”) regarding the use of Luminex or third party software product provided to you by Luminex or its authorized reseller, which includes computer software, scripts, algorithms, and online or electronic documentation and may include associated media and printed materials (if any) (“SOFTWARE”). The terms also apply to any updates, supplements, web content or Internet-based services, such as remote access.

BY USING, INSTALLING, OR ACCESSING THE SOFTWARE, YOU ACCEPT THESE TERMS. IF YOU DO NOT ACCEPT THESE TERMS, DO NOT USE, INSTALL, AND/OR ACCESS THE SOFTWARE. INSTEAD, RETURN IT TO LUMINEX OR THE LUMINEX AUTHORIZED RESELLER FROM WHICH YOU PURCHASED OR OBTAINED THE SOFTWARE (IF APPLICABLE, FOR A REFUND OR CREDIT). IF YOU COMPLY WITH THESE LICENSE TERMS, YOU HAVE THE RIGHTS TO USE THE SOFTWARE AS SPECIFICALLY SET FORTH BELOW.

1. **OVERVIEW.** The SOFTWARE is protected by copyright laws and international copyright treaties, as well as other intellectual property laws and treaties. The SOFTWARE is licensed, not sold.
2. **ADDITIONAL LICENSING REQUIREMENTS AND/OR USE RIGHTS.**
 - a. **Trial and Conversion.** Some or all of the SOFTWARE may be licensed on a trial basis. Your rights to use trial SOFTWARE are limited to the trial period. The trial SOFTWARE and length of the trial period are set forth during the activation process or otherwise set forth in a written agreement between Luminex and you. The SOFTWARE may be used for evaluation purposes only during the trial period and not for any commercial use, including without limitation to any diagnostic use. You may have the option to convert your trial rights at the expiration of your trial period.
 - b. **Activation.** For certain SOFTWARE, you can activate the SOFTWARE by obtaining a license key provided by Luminex Technical Support at support@luminexcorp.com or 1-877-785-2323 or 1-512-381-4397.
 - c. **Branding.** You may only add additional branding or other graphics to SOFTWARE with Luminex's express written consent. For certain SOFTWARE, Luminex may permit you to upload your logo onto the SOFTWARE pursuant to the instructions and terms provided by Luminex.
 - d. **Upgrades.** You may only obtain updates or upgrades for the SOFTWARE from Luminex Technical Support at orders@luminexcorp.com or authorized resellers. For certain SOFTWARE, Luminex may permit downloading updates or upgrades from a Luminex authorized Website. For more information on obtaining updates from authorized resellers, see <http://www.luminexcorp.com>.
3. **GRANT OF LICENSE.** Subject to the terms and conditions of this EULA, Luminex hereby grants to you a non-exclusive, non-transferable, non-assignable license (without right to sublicense) under Luminex's copyrights and trade secrets to use the SOFTWARE on a single instrument if the software is embedded in the instrument or on a single computer running with a single unit of a specific model of Luminex instrument, as such model is identified on the packaging included with the SOFTWARE. For certain SOFTWARE that is not integrated into a Luminex instrument and provided on a separate medium and/or does not require activation, you may make one (1) copy of the SOFTWARE for backup or archival purposes only. For some of such SOFTWARE, you may also install the SOFTWARE on up to two (2) additional computers for purposes of performing ancillary tasks (i.e. preparing templates/protocols, performing further analysis or re-running previous data), provided such computers are at a single location and are NOT connected with a Luminex instrument. In addition, you may purchase the right to use the SOFTWARE on additional computers, as agreed to in writing with Luminex or its authorized reseller, for purposes of performing ancillary tasks (i.e.

preparing templates/protocols, performing further analysis or re-running previous data), provided such computers are at a single location and are NOT connected with a Luminex instrument. No rights or licenses under any of Luminex's patents are granted by or shall be implied from the license of the SOFTWARE or the sale of a Luminex instrument to you.

4. **RESTRICTIONS.**

- a. You will use the SOFTWARE for laboratory research and evaluation purposes only and you will not use the SOFTWARE for any diagnostic use and/or commercial applications or purposes, including without limitation performance of testing services, unless expressly agreed to in writing by Luminex.
- b. SOFTWARE must only be installed and operated on a single computer running with or in connection with a Luminex instrument, as set forth above.
- c. You may not use this SOFTWARE for any commercial purpose, including in the performance of testing services, unless expressly agreed to in writing by Luminex or as authorized in writing by Luminex through an authorized reseller of the SOFTWARE.
- d. You may only use the SOFTWARE with microspheres, cassettes and cartridges authorized by Luminex or with kits developed, manufactured and distributed by Luminex or by licensees authorized in writing by Luminex. This restriction 2(d) does not apply to the Amnis, Guava, Muse and FlowCollect branded Luminex products and updates thereto.
- e. You must maintain all proprietary notices on all copies of the SOFTWARE.
- f. You may not distribute copies of the SOFTWARE to third parties.
- g. You may not reverse-engineer, decompile, disassemble, or otherwise attempt to derive source code from the SOFTWARE.
- h. You may not copy (other than one backup or archival copy), sell, distribute, sublicense, rent, lease, transfer or grant any rights in or to all or any portion of the SOFTWARE.
- i. You must comply with all applicable laws and regulations, including Food and Drug Administration requirements, regarding the use of the SOFTWARE.
- j. You may not modify or prepare derivative works of the SOFTWARE, including modifying any branding or graphics.
- k. You may not use the SOFTWARE in a computer-based service business, in the operation of a service bureau, or otherwise for the benefit of any third party, or publicly display visual output of the SOFTWARE.
- l. You may not transmit the SOFTWARE over a network, by telephone, or electronically by any means.
- m. You acknowledge your obligation to inform your employees, consultants, and associates who will be using the SOFTWARE, of Luminex's labeling literature, warnings, instructions, notices, and other materials regarding proper use that Luminex has provided or may hereafter provide to you.

5. **TERM AND TERMINATION.** Your rights under this EULA are effective until termination. You may terminate this EULA at any time by destroying the SOFTWARE, including all computer programs and documentation, and erasing any copies residing on your computer equipment if the software is not embedded in the instrument. Luminex may terminate this EULA upon thirty (30) days written notice to you. Your rights under this EULA automatically terminate without further action on the part of Luminex if you do not comply with any of the terms or conditions of this EULA. Upon any termination of this EULA, you agree to destroy the SOFTWARE and erase any copies residing on your computer equipment.

6. **RIGHTS IN SOFTWARE.** All rights and title in and to the SOFTWARE and any copies thereof are owned by Luminex or its suppliers. This EULA is not a sale and does not transfer to you any title or ownership interest in or to the SOFTWARE or any patent, copyright, trade secret, trade name, trademark or other intellectual property right therein. You shall not remove, alter, or obscure any proprietary notices contained on or within the SOFTWARE and shall reproduce such notices on any back-up copy of the SOFTWARE. All title and intellectual property rights in and to the content which

may be accessed through use of the SOFTWARE is the property of the respective content owner and may be protected by applicable copyright or other intellectual property laws and treaties. This EULA grants you no rights to use such content.

7. **EXPORT RESTRICTIONS.** You agree that you will not export or re-export the SOFTWARE to any country, person, entity, or end-user subject to U.S.A. export restrictions or in a manner that is contrary to any local, provincial, state, national, international, and foreign laws or regulations applicable to you. You hereby warrant no state or federal agency has suspended, revoked, or denied your export privileges.
8. **NO WARRANTY.** THE SOFTWARE IS LICENSED "AS IS, WHERE IS." ANY USE OF THE SOFTWARE IS AT YOUR OWN RISK WITHOUT WARRANTY OF ANY KIND. THE SOFTWARE IS PROVIDED FOR USE ONLY WITH LUMINEX PRODUCTS. TO THE MAXIMUM EXTENT PERMITTED BY APPLICABLE LAW, LUMINEX AND ITS SUPPLIERS DISCLAIM ALL CONDITIONS, TERMS, REPRESENTATIONS, AND WARRANTIES, EITHER EXPRESS OR IMPLIED, STATUTORY OR OTHERWISE, INCLUDING BUT NOT LIMITED TO IMPLIED WARRANTIES OF MERCHANTABILITY, QUALITY, FITNESS FOR A PARTICULAR PURPOSE, TITLE, OR NONINFRINGEMENT OF INTELLECTUAL PROPERTY.
9. **LIMITATION OF LIABILITY.** IN NO EVENT SHALL LUMINEX, ITS AFFILIATES, LICENSORS, AUTHORIZED DISTRIBUTORS, OR SUPPLIERS BE LIABLE FOR ANY SPECIAL, INCIDENTAL, INDIRECT, OR CONSEQUENTIAL DAMAGES WHATSOEVER (INCLUDING, WITHOUT LIMITATION, DAMAGES FOR LOSS OF BUSINESS PROFITS, BUSINESS INTERRUPTION, LOSS OF BUSINESS INFORMATION, OR ANY OTHER PECUNIARY LOSS) ARISING OUT OF THE USE OF OR INABILITY TO USE THE SOFTWARE, OR THE RESULTS OF THE USE OF THE SOFTWARE, WHETHER BASED IN CONTRACT, TORT (INCLUDING NEGLIGENCE OR STRICT LIABILITY), OR ANY OTHER LEGAL THEORY, AND EVEN IF LUMINEX, ITS AFFILIATES, LICENSORS, AUTHORIZED DISTRIBUTORS, OR SUPPLIERS HAVE BEEN ADVISED OF THE POSSIBILITY OF SUCH DAMAGES. YOU ACKNOWLEDGE THAT THE "AS IS" AND LIMITATION ON LIABILITY PROVISIONS CONTAINED IN THIS AGREEMENT CONSTITUTE MATERIAL TERMS OF THE CONTRACTUAL BARGAIN BETWEEN THE PARTIES AND THAT NO LICENSE WOULD BE PROVIDED IN THE ABSENCE OF SUCH PROVISIONS.
10. **YOUR REPRESENTATION AND INDEMNITY.** You represent and warrant that you shall use the Software in accordance with the terms of this Agreement, and that any such use of the Software will not violate any law, regulation, judicial order or injunction. You agree to defend, indemnify and hold Luminex and its authorized resellers and licensors, and each of their respective officers, directors, employees, agents, successors and assigns harmless from and against any loss, damage, claim, cost, expense or other liability (including, without limitation, legal fees and amounts reasonably paid in settlement) suffered or incurred by Luminex as a result of any claim or cause of action by a third party arising out of, based upon or relating to: (i) your use of the SOFTWARE, (ii) your use of or reliance on any evaluation, analytic results or other data derived from the SOFTWARE, or (iii) any breach by you or any of your representatives of the terms of this Agreement.
11. The SOFTWARE is a "commercial item," as that term is defined in 48 C.F.R. 2.101 (Oct. 1995), consisting of "commercial computer software" and "commercial computer software documentation," as such terms are used in 48 C.F.R. 12.212 (Sept. 1995). Consistent with 48 C.F.R. 12.212 and 48 C.F.R. 227.7202-1 through 227.7202-4 (June 1995), all U.S. Government end users acquire the SOFTWARE with only those rights set forth herein.
12. **MISCELLANEOUS.** This EULA is governed by the laws of the State of Texas, U.S.A., without reference to conflicts of laws principles. The United Nations Convention on Contracts for the International Sale of Goods does not apply. You shall not assign or sublicense or otherwise transfer the rights or license granted hereunder, by agreement or by operation of law, without the prior written consent of Luminex, and all assignments in violation of this prohibition shall be null and void. This EULA is the complete and exclusive agreement of Luminex and you and supersedes all other communications, oral or written, relating to the subject matter hereof. No change to this EULA shall be valid unless in writing and signed by the party against whom enforcement is sought. The waiver or failure of Luminex or you to exercise in any respect any right or rights provided for herein shall not be

deemed a waiver of any further right hereunder. If any provision of this EULA is held unenforceable, the remainder of this EULA will continue in full force and effect.

For translations of this document, see <http://www.luminexcorp.com>.

89-30000-00-419 Rev. G

Table of Contents

Chapter 1: Introduction

Instrument	1
Software	2
Cassettes	2
Warnings and Notes	2
Symbols	2
Luminex Technical Support	4

Chapter 2: Safety and Regulatory Considerations

Testing and Certification	5
Safety Precautions	5
Electromagnetic Compatibility	6
Lasers	6
Biological Samples	6
Chemical Hazards	7
Mechanical Components	7
Electrical Components	7
Heat	7
Disposal of Instrument	8

Chapter 3: Principles of Operation

Major System Components	9
General System Workflow	9
System Components	9
ARIES® Software	10
Cassettes	10
ARIES® M1 System	12
Instrument Subsystems	14
Electronics	14
Mechanics	15
Optics	15
Recommended Additional Equipment	15
Uninterruptible Power Supply (UPS) or Surge Protector	15
Optional Additional Equipment	16
Barcode Labels	16

Chapter 4: Specifications and Limitations

General	17
Electronics	19

Chapter 5: Installation

Installation	20
Site Preparation and Facilities Requirements	21
Installing the Hand-held Barcode Reader	21
Installing the Luminex Supplied Printer	21
Installing a Network Printer	22
System Calibration	22
Installation Diagram	23

Chapter 6: Operating Instructions

Initializing the ARIES® M1 System	24
ARIES® M1 System Status Screen	24
Logging into the ARIES® M1 System using your ID Badge	26
Changing your Password	26

Chapter 7: Run

Run Page	27
Color Definitions	29
Starting a Run with Auto Run Enabled	33
Starting a Run Manually	34
Aborting a Run	35
Clearing the Module	35
Adding a Sample Comment to a Cassette from the Run Page	35
Entering the Cassette Information Manually on the Run Page	36
Run Settings Page	37
Enabling or Disabling Auto Run	37
Assigning Default Names for Required Sample Identifiers to Cassettes	38
Setting the Display Run Time	38
Enabling or Disabling the Module	38

Chapter 8: Results

Results Page	40
Viewing Results	40
Creating a Report	40
Exporting Results	41
Filtering Results	41
Grouping by Run or Grouping by Sample	42
Resetting Filters	42
Adding a Sample Comment to a Result from the Re-	

sults Page	42
Submitting to the LIS	43
Renaming a Run	43
Editing a Sample	43
Generating a Grid Report	44
Results Settings Page	44
Generating Reports After a Run	45
Setting Up to Automatically Export a Summary Report as CSV	45
Setting Up to Automatically Export a Sample Report as PDF	46
Setting Up to Automatically Print Sample Reports After a Run is Complete	46

Chapter 9: Order Management

Sample Orders Page	47
Associating Cassettes to Samples	47
Creating a New Order	47
Creating a Control Order	48
Editing an Order	49
Importing Orders	49
Exporting Orders	50
Deleting Orders	50
Filtering Orders	50
Resetting Filters	51
Generating a Grid Report	51
Duplicate Orders Page	51
Editing a Duplicate Order	53
Deleting a Duplicate Order	53
Applying Results to a Duplicate Order	53
Order Management Settings Page	54
Making Sample Options Required and/or Visible for an Order	54
Enabling Duplicate Orders	54

Chapter 10: Assay Management

Assay Management Page	56
Importing Assay Files to the ARIES® M1 System	56
Deleting an Assay	57
Setting up Report and Graph Options	57
Generating a Grid Report	58
Controls Page	58
Creating a Control Lot	58
Editing a Control Lot	59
Deleting a Control Lot	59

Chapter 11: Security

Audit Log Page	60
Filtering the Audit Log	60
Resetting Filters	61
Generating a Grid Report	61

User Management Page	61
Creating Users	61
Editing Users	62
Changing a User's Status	62
Changing a User's Password	63
Group Management Page	63
Assigning Permissions	63
Security Settings Page	64
Changing the User Settings	64
Changing the System Settings	64
Changing the Password Settings	65

Chapter 12: Administration

Lab/Site Information Page	66
Changing the Instrument Display Name	66
Changing the Instrument Icon	67
Customizing the Report Headers for Reports	67
Customizing the Report Logo	68
Data Maintenance Page	68
Setting up the Archive	69
Performing a Backup	70
Restoring the Database	70
Starting the Archive	71
Sample Comments Page	71
Creating Sample Comments	72
Editing Sample Comments	72
Deleting Sample Comments	73
Generating a Grid Report	73
Scheduled Maintenance Page	73
Creating a New Reminder	74
Editing a Reminder	74
Deleting a Reminder	74
LIS Settings Page	75
Selecting an LIS Format	75
Automatically Exporting to LIS	75
Automatically Importing from LIS	76
Administration Settings Page	76
Managing Printers	77
Installing Network Drives	77
Setting Network Settings	78
Setting the Date and Time	78
Installing Software Updates	78

Chapter 13: System

System Log Page	80
Generating a Grid Report	80
Filtering the System Log	80
Resetting Filters	81
System Information Page	81
Instrument Status Page	81
Generating a Grid Report	83
Support Page	83
Exporting a Support Package	83

System Settings Page	84
Changing the Audio Settings	84
Enabling Persist Filters	85

Chapter 14: Maintenance

General Maintenance Precautions	86
12 Month Preventative Maintenance	86
Routine Maintenance	86
Sample Prep Tray Decontamination	86
Daily Decontamination	87
As Needed Maintenance	87
Shutting Down the ARIES® M1 System	87
ARIES® M1 System Decontamination	87
Replacing the Power Cord	88
Replacing Fuses	88

Chapter 15: Troubleshooting

Appendix A: Shipping

Shipping	93
Shipment Checklist	93

Appendix B: Part Numbers

Hardware	94
Disinfecting Supplies	94

Chapter 1: Introduction

The Luminex® ARIES® M1 System is a fully integrated, sample to answer platform that performs real-time PCR assays. The ARIES® M1 System extracts, amplifies and detects nucleic acid targets from a variety of sample types. Once the cassettes are loaded onto the instrument, results are generated without additional technical intervention.

Instrument

The ARIES® M1 System can process up to six different samples at a time. The instrument contains one module, with the ability to run one to six different assays that run according to the ARIES® Universal Protocol. The ARIES® M1 System comprises of the following:

- A one module bench top instrument, with a magazine to accommodate six disposable single-use assay cassettes
- A module that includes a six-channel real-time PCR optical system
- Touch screen user interface that includes the software for running and analyzing assays



Software

The ARIES[®] Software is a graphical user interface (GUI) application that is the end-user interface to the ARIES[®] M1 System. The software is installed in an embedded computer. The ARIES[®] Software is responsible for providing the environment in which a user runs assays and obtains results. Optionally, the system is capable of interfacing with a Laboratory Information System (LIS).

	WARNING: Using unauthorized third-party software with ARIES [®] Software may result in corruption or failure of the ARIES [®] Software. Do not use third-party software on the ARIES [®] M1 System.
---	---



Cassettes

The module has one magazine capable of holding up to six cassettes. Cassettes are single-use only and have a closed design that prevents cross-contamination. The sample and reagents in the cassettes do not have direct contact with the instrument or other assays running on the system. Cassettes can hold various sample volumes depending on the assay being run. The cassettes are designed for multiple sample types (e.g., serum, plasma, whole blood, Cerebrospinal fluid (CSF), sputum, stool, and swabs (in transport media)). Each cassette is prefilled with the following:

- Nucleic acid extraction reagents
- Sample Processing Control (SPC)
- Lyophilized Master Mix

Warnings and Notes















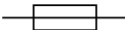









The following warnings and notes appear as necessary in this manual.

NOTE: This message is used to provide general helpful information. No safety or performance issues are involved.	
	CAUTION: This message is used in cases where the hazard is minor or only a potential hazard is present. Failure to comply with the caution may result in hazardous conditions.
	WARNING: This message is used in cases where danger to the operator or to the performance of the instrument is present. Failure to comply with the warning may result in incorrect performance, instrument failure, invalid results, or hazard to the operator.
	DANGER: This message is used in cases where significant risk of serious injury or death is present.

Symbols

You may encounter these symbols throughout this manual. They represent warnings, conditions, identifications, instructions, and regulatory agencies.

TABLE 1. Symbols

Symbol	Meaning	Symbol	Meaning	Symbol	Meaning
	Hand Crush / Force From Above		Serial number		WEEE Symbol
	Caution, risk of electric shock		Temperature Limit Indicates the temperature limits to which the medical device can be safely exposed.		Fuse
	Use-by date		Biological risks		EPUP Symbol
	Manufacturer		Burn Hazard/Hot Surface		Caution
	Stand-by Power on/off		Consult instructions for use.		Protective earth; protective ground
	Caution hot surface		Catalog(ue) Number		Alternating Current
	Warning; Laser Beam		Batch Code		Do not reuse
	For Research Use Only. Not for use in Diagnostic Procedures		MET NRTL Certification Mark		Conformite Europeenne (EU CE Marking of Conformity)
	Authorized representative in the European Community				

Luminex Technical Support

Contact Luminex Technical Support by telephone in the U.S. and Canada by calling: 1-877-785-(2323)

Contact outside the U.S. and Canada by calling: +1 512-381-4397

International: + 800-2939-4959

Fax: 512-219-5114

Email: support@luminexcorp.com.

Additional information is available on the Luminex website. Search on the desired topic, navigate through menus. Also, review the website's FAQ section. Enter <http://www.luminexcorp.com> in your browser's address field.

Chapter 2: Safety and Regulatory Considerations

Testing and Certification

The ARIES[®] M1 System has been tested by an OSHA Nationally Recognized Testing Laboratory (NRTL) which is also an Accredited Certification Organization by the Standards Council of Canada. In addition, ARIES[®] M1 System complies with European Union (EU) regulations and therefore can be marketed in the European Single Market. The following European Union compliance label appears on the back of the ARIES[®] M1 System.

FIGURE 1. European Union Compliance Label





FIGURE 2. Safety Label



Safety Precautions



Do not perform procedures on the ARIES[®] M1 System that are not specifically described in this manual or package inserts, unless you are directed to do so by Luminex Technical Support. Read the following safety information before using the ARIES[®] M1 System. This instrument contains electrical, mechanical, and laser components that, if handled improperly, are potentially harmful. In addition, biological and chemical hazards can be present during system operation. Therefore, Luminex recommends that all system users become familiar with the specific safety advisories below in addition to adhering to standard laboratory safety practices.

NOTE: In any situation in which you encounter this symbol:  consult this manual or other Luminex documentation to determine the nature of the potential hazard and any necessary actions you must take.	
	CAUTION: The protection provided by the equipment can be impaired or the warranty voided if the ARIES [®] M1 System is used in a manner not specified by the instructions or by Luminex Corporation.
	CAUTION: Do not open the access door at any time. Do not place your hand inside the module opening at any time.

Always observe standard laboratory safety practices.



Electromagnetic Compatibility

ARIES[®] M1 System has been tested by Professional Testing Incorporated (PTI) and complies with the Electromagnetic Interference (EMI) requirements for the United States, European Union, and Canada.

	WARNING: Do not use this device in close proximity to sources of strong electromagnetic radiation (e.g., unshielded intentional RF sources), as these may interfere with proper operation.
	WARNING: Always handle the ARIES [®] M1 System according to Luminex instructions to avoid any possible interference from its electromagnetic fields.
	WARNING: This instrument contains magnets. Persons with pacemakers should use caution when operating. Do not insert any object into the magazine opening other than the magazine.

Lasers

The ARIES[®] M1 System is a Class I laser product per FDA 21 CFR 1040.10 and 1040.11. The accessory barcode reader may include a Class II laser. In accordance with IEC 60825-1:2007 and IEC 60825-1:2014, the instrument is classified as Class 1, containing a Class II (2) laser, and the accessory barcode reader may include a Class 2 laser. The ARIES[®] M1 System complies with IEC 60825-1:2007 and IEC 60825-1:2014 and 21 CFR 1040.10 and 1040.11 except for deviations pursuant to Laser Notice No. 50, dated June 24, 2007. The laser explanatory label appears on the rear panel of the ARIES[®] M1 System.

	DANGER: Do not, under any circumstances, remove the ARIES [®] instrument cover. Use of controls, adjustments, or performance of procedures other than those specified in this manual can result in hazardous radiation exposure.
	DANGER: Do not stare into the laser beam or shine it into other people's eyes. See the operating instructions provided with the barcode reader for more safety information.



Biological Samples

	Human and animal samples may contain biohazardous infectious agents. Where exposure to potentially biohazardous material—including aerosol—exists, follow appropriate biosafety procedures and use personal protective equipment (PPE). PPE includes gloves, gowns, laboratory coats, face shields or mask and eye protection, respirators, and ventilation devices. Observe all local, state, federal, and country specific biohazard handling regulations when disposing of biohazardous waste material.
---	--



Chemical Hazards

	CAUTION: Adhere to standard laboratory safety practices when handling hazardous, toxic, or flammable reagents and chemicals. Contact Luminex Technical Support when in doubt about compatibility of cleaning and decontamination agents or materials.
---	--

Mechanical Components

	WARNING: The ARIES® M1 System has parts that move during operation. Risk of personal injury is present. The moving parts present pinching and hand-crushing hazards.
	WARNING: Observe all warnings and cautions. Do not place your hands inside the module openings at any time. Do not open the access door at any time.

Electrical Components

	WARNING: Do not perform any maintenance or cleaning of the electrical components in the system, with the exception of replacing fuses. Power cords must be replaced with cords of the same type and ratings as originally provided. Contact Luminex Technical Support for correct replacement power cords.
	WARNING: Do not block access to the power cord at the back of the instrument.

The fuse caution label is located on the back of the ARIES® M1 System.

The voltage label is located on the back of the ARIES® M1 System. It displays the serial number, model number, power requirements, and manufacturer's information.

Heat

The ARIES® M1 System can heat cassette samples up to 95°C.

	CAUTION: Use caution, the magazine and cassettes may be hot when removed from the instrument and can cause personal injury if touched. Do not put your hand inside the module opening.
---	---

Disposal of Instrument

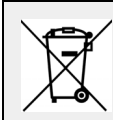

NOTE: Within the European Union and other jurisdictions, in accordance with the European Parliament and of the Council regarding Waste Electrical and Electronic Equipment (WEEE), you must properly dispose of electrical and electronic equipment when it reaches its end of life.

If you are disposing of an ARIES® M1 System, decontaminate the system. See section, “*As Needed Maintenance*” on page 87. Next, contact Luminex Technical Support for a Return Material Authorization (RMA) number at 1-877-785-2323 (within the U.S.) and +1-512-381-4397 (outside of the U.S.). Return the equipment to the following Luminex location:

Luminex Corporation

12201 Technology Blvd., Suite 130

Austin, Texas 78727

USA

Chapter 3: Principles of Operation

Major System Components

- Instrument
- One magazine
- Cassettes (up to six)
- Sample Prep Tray
- Software

General System Workflow

1. The user imports the assay protocol file onto the system from the USB flash drive that is provided with the assay kit.
2. The user identifies the sample to be tested and places the sample tube in the Sample Prep Tray.
3. The user removes the assay cassette from its packaging, removes the back seal, and places the cassette in the Sample Prep Tray next to the sample.
4. The user adds the sample via a pipette into the cassette and closes the cassette cap firmly.
5. The user creates a new order and picks up the cassette and scans the barcode on top or on the side of the cassette with the hand-held barcode reader to populate the cassette information.
6. The user picks up the sample tube and scans the sample with the hand-held barcode reader to populate the Sample ID field. Based on order settings the user might also need to provide the Accession ID and Requisition Number.
7. This is repeated as needed for up to six cassettes. The cassettes are then transferred from the Sample Prep Tray to the magazine.
8. The user places the magazine into the module. The instrument scans the barcode located on the top of the cassette and automatically configures to perform the appropriate assay based on the unique barcode on the cassette.



CAUTION: Do not obstruct the top barcode of the cassette.

9. The instrument completes all necessary steps for the assay. No user intervention is necessary once the sample is loaded into the system.
10. The user can monitor the status of the assay via the touch screen on the instrument, which displays the current processing stage (e.g., Sample Prep, PCR Cycle) and the display run time.
11. Once the run is complete, the user removes the magazine and disposes of the cassettes in the appropriate waste container.
12. Results can be reviewed by the user on the touch screen, printed, or submitted to an LIS for reporting.

System Components

The following topics describe details of the three system components: ARIES® Software, Cassettes, and ARIES® M1 System.

ARIES® Software

To receive a faxed, mailed, or emailed copy of the *ARIES® M1 System Operation Manual*, contact Luminex Technical Support. The software user information is documented in two ways:

- Instrument Help, which is preloaded on the system.
- Manual in PDF form, which is available on the Luminex website and on the USB included with the system.

	<p>WARNING: Using unauthorized third-party software with ARIES® Software may result in corruption or failure of the ARIES® Software. Do not use third-party software on the ARIES® M1 System.</p>
---	--







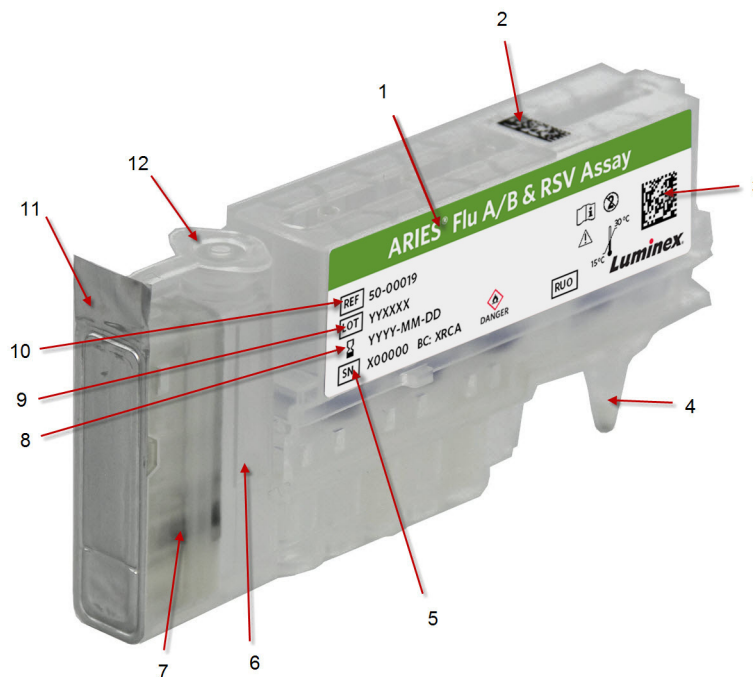

Cassettes

Cassettes are single-use only and have a closed design that prevents cross-contamination.

FIGURE 3. ARIES® Cassette



1	Assay type	6	Sample chamber	11	Back seal
2	Cassette barcode (top)	7	Side cassette	12	Cassette cap
3	Cassette barcode (side)	8	Cassette expiration date		
4	PCR tube	9	Cassette lot number		
5	Cassette serial number	10	Cassette part number		

	CAUTION: Adhere to standard laboratory safety practices when handling hazardous, toxic, or flammable reagents and chemicals. Consult the package insert for the assay you are running and the Safety Data Sheet (SDS) for more information. Contact Luminex Technical Support when in doubt about compatibility of cleaning and decontamination agents or materials.
	WARNING: Cassettes contain a small amount of isopropanol, which is a flammable liquid. Keep away from heat, open flames, and sparks in a well-ventilated area. Remove them from the instrument when not in use.
	WARNING: If a cassette appears damaged in any way or if you see any leaks, DO NOT USE THE CASSETTE . Immediately contact Luminex Technical Support to report the damage.
	WARNING: Do not use a cassette for anything other than its intended purpose. Mishandling or improper use of a cassette may cause incorrect results. Cassettes are single-use only, do not reuse a cassette. Dispose of all used cassettes in the appropriate waste container.
	WARNING: Failure to ensure that the cassette cap is fully closed may cause a delay or failure in results and expose the user to biohazards.
	CAUTION: Only use cassettes or other consumables that are within their expiration date. Dispose of all expired cassettes or consumables in the appropriate waste container.
	CAUTION: Use caution when pulling the back seal off the cassettes. The foil is sharp and may cause injury.
	CAUTION: Refer to the applicable SDS regarding safe handling practices for any spills.

Cassette Workflow

The following steps all take place within the closed cassette inside the ARIES[®] M1 System:

1. **Sample Preparation** - The samples are mixed with lysis reagents. The samples then go through a series of washes to capture and purify the nucleic acid. The nucleic acid is then transferred into the PCR tube.
2. **PCR** - The ARIES[®] M1 System initiates a PCR process, which heats and cools the PCR tube for denaturation and replication of the nucleic acid.
3. **Detection** - The ARIES[®] M1 System detects changes in fluorescence to determine if the target nucleic acid is present.

ARIES® M1 System

The ARIES® M1 System includes the following hardware:

- The ARIES® instrument
- One magazine
- Two Sample Prep Trays
- One hand-held barcode reader

Sample Prep Tray

The Sample Prep Tray (SPT) is a tool that can assist you in preparing the cassette for a run. The SPT can accommodate various sample tube sizes and hold up to six cassettes at a time. Do not remove the cassettes from the SPT until you are ready to insert them into the magazine.



	<p>CAUTION: Avoid dropping the SPT and magazine. Take care when transporting samples to the instrument. Follow your standard laboratory safety practices when handling hazardous materials.</p>
---	--

FIGURE 4. Sample Prep Tray



Magazine Workflow

	<p>WARNING: Do not use your index finger to push the cassette into the magazine. You may indirectly dispense the reagents. Luminex recommends using the palm of your hand or holding the cassette and sliding it into the proper position.</p> 
---	--

1. After the sample has been added to the cassette and the cap has been securely closed, line the cassette up with the notch located on the magazine (there is a tab on the end of the cassette that fits into the notch). The PCR tube must face toward the numbers on the magazine.
2. Gently insert the cassette into the magazine.

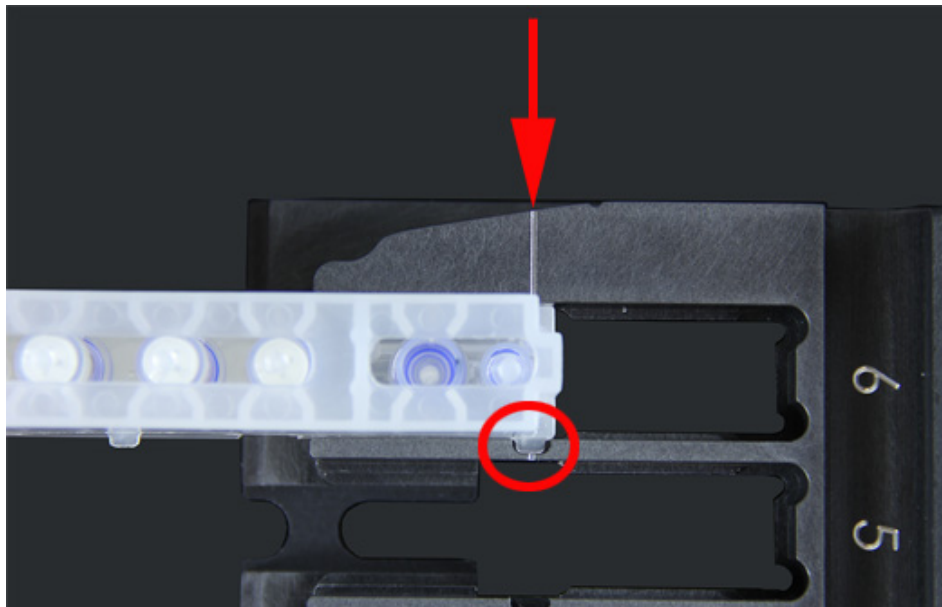

3. Gently slide the cassette all the way toward the numbers. Repeat for all other cassettes. Ensure that the cassettes are fully inserted before putting the magazine into the ARIES® M1 System. Incorrectly inserting the cassettes can cause errors.

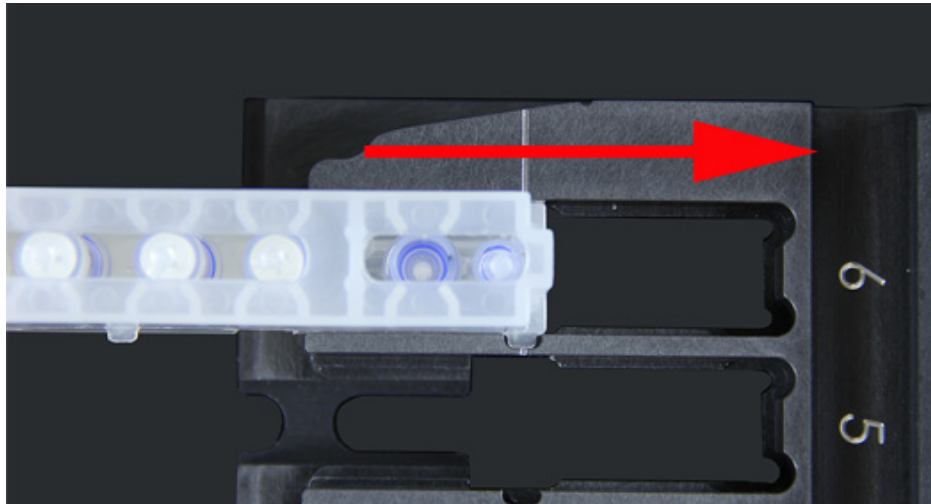

Instrument Subsystems

The ARIES® M1 System includes three subsystems: electronic, mechanical, and optical. The following topics describe the components of each subsystem.

Electronics

The electronics system provides the power for operation and control of the ARIES® M1 System and communication between its parts.



WARNING: Do not open the access door at any time. The access door is only to be opened by a Luminex Field Service Engineer. To avoid any danger of electrical shock, turn off the instrument and unplug the power cord.

Power Input Module

The power input module contains the input power plug and fuses. This is the protective earthing point for the ARIES® M1 System. The mating power cord connector type is IEC-320-C13. The mating power cord provides electrical power to the instrument when it is connected to an electrical outlet and is the means of disconnection. The power input module automatically senses the voltage range.



WARNING: Do not obstruct this means of disconnection. Connect only to outlets that contain protective earthing. Before changing a fuse, turn off the instrument and unplug the power cord to avoid any danger of electrical shock.

Communications Ports

The instrument provides the following communications ports:

	WARNING: Do not plug any external electronic devices into the ARIES® M1 System other than those provided by Luminex. Contact Luminex Technical Support for more information.
---	---

- 5 x USB “Type A” connectors (one on the front of the instrument and four on the back)
- 1 x RJ45 network connection

Mechanics

The mechanical subsystem of the ARIES® M1 System includes an air filter system. The filters will be changed/cleaned once a year by a Luminex Field Service Engineer.

Optics

The optical system consists of the optical assembly and the excitation LEDs. The optical components do not require manual adjustment by the user.

Recommended Additional Equipment

Uninterruptible Power Supply (UPS) or Surge Protector

Luminex recommends using a UPS with a rating of 500 watts/575 VA for locations that have a generator to restore power in case of a power outage. For locations that do not have a backup generator, contact Luminex to discuss recommended battery life requirements.

Optional Additional Equipment

The following optional equipment can be connected by using the USB “Type A” communication ports on the ARIES[®] M1 System:

- Printer
- Keyboard and Mouse



Barcode Labels

The ARIES[®] M1 System has been designed for use with the Data Matrix barcode symbologies. If you are using other symbologies, they should be validated internally. If you have questions about which symbologies are supported by the hand-held barcode reader provided with the ARIES[®] M1 System, contact Luminex Technical Support.

NOTE: ARIES[®] M1 System does not support Unicode characters. Only ASCII characters are acceptable.

Chapter 4: Specifications and Limitations

The ARIES® M1 System is designed to meet specifications for Throughput, Limit of Detection, Dynamic Range, and Reproducibility. The following topics provide the specifications and limitations for the ARIES® M1 System.

	CAUTION: Read and observe specifications and limitations carefully.
	CAUTION: Do not open the access door at any time. Do not place your hand inside the module opening at any time.

General

TABLE 2. **Specification and Limitations**

Indoor laboratory and professional use only	
Physical dimensions:	39.12 cm (15.40 in) wide by 60.66 cm (23.88 in) deep by 64.5 cm (25.4 in) high
Weight:	Approximately 78.5 lbs (35.6 kg)
Installation category:	II
Pollution degree:	2
Operating temperature:	15°C to 35°C (59°F to 95°F)
Operating humidity:	Relative Humidity: 20% to 80%, non-condensing
Shipping and storage temperature:	-25°C to 50°C (-13°F to 122°F)
Shipping and storage humidity:	Relative Humidity: ≤ 90%, non-condensing
Shock/Vibration (For shipping and storage):	shall comply with ISTA Procedure 3B
Temperature control:	Maintains thermal cycling temperature from 55°C to 95°C (131°F to 203°F), within ± 1.0°C
Altitude:	Operation up to 2400 m (7874 ft.) above mean sea level
Automatic real-time analysis	
Analyzes multiple assay protocols per magazine	
Barcode reader entry of sample IDs	
System initialization:	System startup time: approximately 5 minutes
Produces sound pressure levels below 85 dBA	

Operating shock:	<p>The instrument is able to operate while experiencing limited shock.</p> <ul style="list-style-type: none"> • Pulse amplitude: 1 m/s maximum • Pulse direction: along any axis defined by a rear corner of the instrument, in either direction • Reference IEC 60068-2-27 Basic Environmental Testing Procedures Part 2: Tests -Test Ea and Guidance: Shock <p>NOTE: This specification is not meant to comprehensively describe all forms of shock the instrument may be exposed to in use; it is only intended to serve as a measure of the system's robustness.</p> <p>Although the system can withstand a shock pulse as described above without compromising reliable operation, extended exposure to shock whether or not it exceeds the pulse defined above, is not recommended and may result in instrument failure.</p>									
Operating vibration:	<p>The instrument is able to operate while experiencing limited vibration. The direction shall be along any axis defined by a rear corner of the instrument. Sinusoidal vibration is limited to frequency ranges listed in the table below</p> <table border="1" data-bbox="609 798 1364 955"> <thead> <tr> <th><u>Frequency Range</u></th> <th><u>Limit</u></th> <th><u>Type of Limit</u></th> </tr> </thead> <tbody> <tr> <td>0 to 10 Hz</td> <td>0.35 mm ± 10% (0.7 mm peak-to-peak)</td> <td>Displacement</td> </tr> <tr> <td>10 Hz to 100 Hz</td> <td>1 m/s² ± 10%, peak</td> <td>Acceleration</td> </tr> </tbody> </table> <p>Reference IEC 60068-2-27 Environmental Testing Procedures Part 2: Tests - Test Fc: Vibration (Sinusoidal).</p> <p>NOTE: Although the instrument can operate while experiencing vibration as described above, extended exposure to vibration, whether or not it exceeds these limits, is not recommended and may result in instrument failure.</p>	<u>Frequency Range</u>	<u>Limit</u>	<u>Type of Limit</u>	0 to 10 Hz	0.35 mm ± 10% (0.7 mm peak-to-peak)	Displacement	10 Hz to 100 Hz	1 m/s ² ± 10%, peak	Acceleration
<u>Frequency Range</u>	<u>Limit</u>	<u>Type of Limit</u>								
0 to 10 Hz	0.35 mm ± 10% (0.7 mm peak-to-peak)	Displacement								
10 Hz to 100 Hz	1 m/s ² ± 10%, peak	Acceleration								
Throughput:	Ability to process 6 cassettes in approximately 2 hours									
Limit of detection:	<p>Five of the six spectral channels are able to accurately distinguish ≤ 10 nM of dye above the background mean + 3 STDEV. 10 nM ≥ (Background mean + 3 STDEV)</p> <p>The Ultraviolet spectral channel is able to accurately distinguish ≤ 40 nM of dye above the background mean + 3 STDEV. 40 nM ≥ (Background mean + 3 STDEV)</p>									
Temperature resolution:	The instrument is able to distinguish 2 amplicons with T _m values within 2°C of each other within the same spectral channel.									
Dynamic range:	The instrument linear dynamic range is ≥ 3.0 decades.									
Sample volume max:	Follow the assay-specific package insert for the appropriate sample volume.									

Reproducibility/ variation:	The C_t values for DNA Sample Processing Control has a standard deviation of ≤ 1.2 across multiple slots and multiple instrument modules. The T_m values for Sample Processing Control in UTM has a maximum standard deviation of $\leq 0.4^\circ\text{C}$ absolute across multiple slots and multiple instrument modules.
British thermal units (BTU):	850 BTU

Electronics

TABLE 3. **Electronics**

USB 2.0-compatible communications link for fast data transfer
Input power: 100 - 240 V~, 4A 50/60 Hz

Chapter 5: Installation

A Luminex Field Service Engineer handles the packing, shipping, unpacking, and installation of the ARIES® M1 System. Luminex recommends that users and laboratory personnel do not install, move, or uninstall the system. If the instrument needs to be moved, contact Luminex Technical Support.

For site preparation and facilities requirements, see section “*Installation*” on page 20.

FIGURE 5. ARIES® M1 System on a Workbench

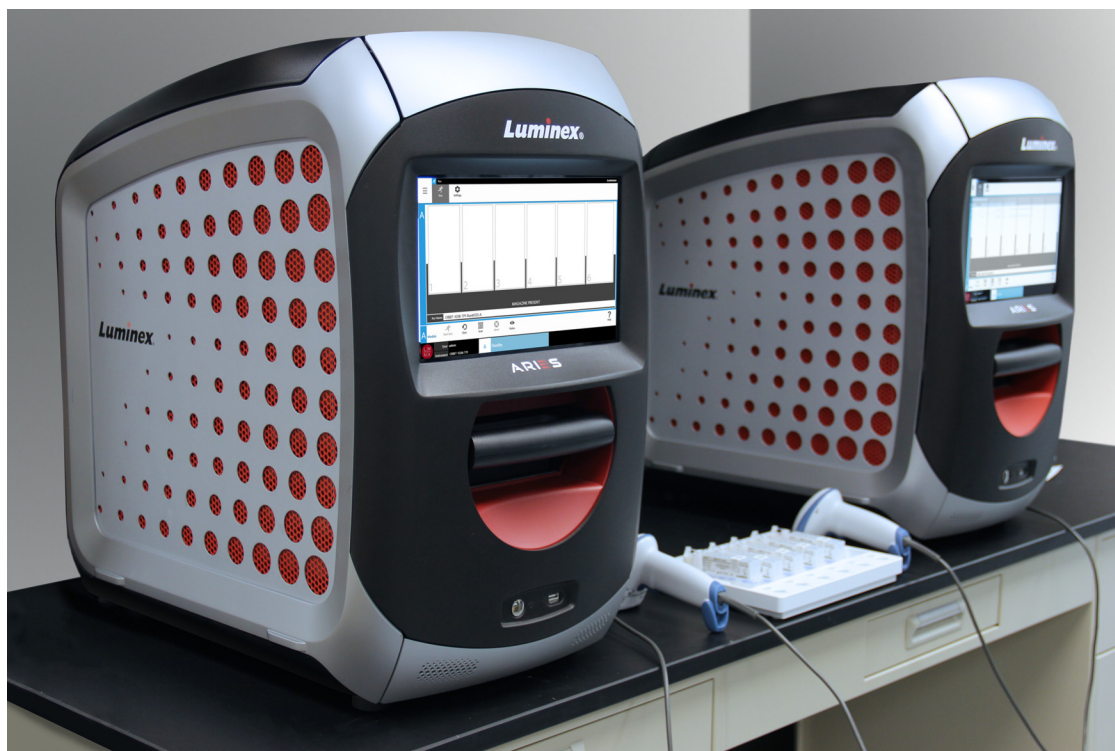



Installation

The following installation instructions for the ARIES® M1 System are to be used for site preparation, assessing facility requirements, and reconnecting cable, if necessary.

NOTE: If you do not intend to keep the packing material for future use, return the packaging of the product, spare parts, and options to the manufacturer with the Field Service Engineer. Within the European Union and other jurisdictions, in accordance with the *European Parliament and Council* regarding packaging and packaging waste, the manufacturer is responsible for the disposal of packing material.



CAUTION: Ensure the capability of secure data transfer to and from the system by only connecting to a secure network.

	CAUTION: The ARIES® M1 System is designed to be stable on a flat surface. Follow local precautions regarding transient natural events.
	WARNING: The ARIES® M1 System is top-heavy. Use caution when installing or moving the instrument. Do not drop or tip the instrument over.

Site Preparation and Facilities Requirements

TABLE 4. Site Preparation and Facilities Requirements

Hallways and doorways:	Minimum 43 in or 110 cm wide
Counter space:	24.25 in x 15.5 in x 37.5 in or 61.6 cm x 39.37 cm x 95.25 cm
Wall clearance:	2 in or 5.08 cm
Counter space must accept weight of:	Approximately 78.5 lbs or 35.6 kg
Shipping box size:	39 in x 29 in x 44 in or 99.1 cm x 73.66 cm x 111.76 cm
Electrical Outlet for a standard power cord (U.S. 120 volts):	Within 6 feet or 1.8 meters of instrument

Installing the Hand-held Barcode Reader

	DANGER: Do not stare into the laser beam or shine it into other people's eyes. See the operating instructions provided with the barcode reader for more safety information.
---	--

1. Plug the barcode reader into one of the four USB connection ports at the back of the ARIES® M1 System.

NOTE: Do not update the barcode reader firmware without contacting Luminex Technical Support.



Installing the Luminex Supplied Printer

For printer installations in the U.S./North America only.

1. Follow the manufacturer's instructions, provided in the printer box, to assemble the printer.
2. Plug the Luminex supplied printer into one of the four USB connection ports at the back of the ARIES® M1 System. The system will automatically recognize the printer.

NOTE: For printers not supplied with the ARIES® M1 System, Luminex recommends disabling the Wi-Fi® functionality to lessen the potential of cyber-security issues. Refer to the manufacturer's instructions provided with the printer to disable the Wi-Fi function.

Installing a Network Printer

1. Log in as **Administrator**.
2. Select  in the upper left-hand corner of the screen and navigate to **Administration > Settings**.
3. Select **Manage Printers**. This requires you to reboot the system into Administration Mode. A message displays asking, "*Changes to these settings require a reboot of the machine. Do you want to reboot now?*" Select **Yes**. The system will now reboot.
4. Once rebooted, select **Manage Printers** again. The **Printers** dialog box opens.
5. Select **Add printer**. The **Add Printer** dialog box opens (this is a Windows® dialog box).
6. Select **Add a network, wireless or Bluetooth printer**. The **Add Printer** dialog box opens.
7. The system will begin searching for an available printer. This may take several minutes.
8. Select **The printer that I want isn't listed**.
9. Under **Find a printer by name or TCP/IP address**, select one of the radio button options. You may need to contact your IT department for required information.
10. Name the printer and select **Next**.
11. The printer is now installed and the system will ask to turn on printer sharing. Select **Do not share this printer**.
12. Print a test page when prompted and select **Finish**.
13. The network printer should now be visible in the **Printers** dialog box. Select the printer.
14. Select **Set as default**. The printer will be highlighted blue and have a small check box with a check next to it.
15. Select **Close**.
16. Once the changes are complete, the system must be rebooted again. Select  from the Page Action bar. A message displays stating, "*The instrument will now commit changes to the hard drive. Manually powering off the instrument during this time can corrupt the disk and prevent the system from starting.*" Select **OK**.

System Calibration

The ARIES® M1 System is calibrated at Luminex Corporation. A calibration verification is performed on-site as part of the installation procedure, as well as during preventive maintenance when under service contract. The calibration verification is performed by a Luminex Field Service Engineer.

Installation Diagram

NOTES:

1. CLEARANCE FOR COOLING (INTAKE AND EXHAUST) AND CABLE CLEARANCE FOR POWER SWITCH ACCESS.
2. LINE CORD SHOULD BE PLUGGED INTO OUTLET WITH PROTECTIVE EARTHING ONLY (REFERENCE USER MANUAL).
3. POWER SWITCH, FUSE MAINTENANCE ACCESS, DEVICE DISCONNECT IS THE POWER CORD. DO NOT POSITION THIS DEVICE SUCH THAT IT IS DIFFICULT TO ACCESS THE DISCONNECT.
4. TOTAL COUNTERTOP WEIGHT: 78.5lbs (35.6kg)
5. FOLLOW SHIPPING AND HANDLING INSTRUCTIONS ON PACKAGING. FOLLOW INSTALLATION INSTRUCTIONS IN SUPPLIED MANUAL.
6. POSSIBLE AEROSOL EXHAUST. 
7. DIMENSIONS IN BRACKETS ARE MILLIMETERS.

REVISIONS			
REV.	ECO NO.	INCORP BY	DATE
A	ECO-11178	S. COLL	2016/02/26

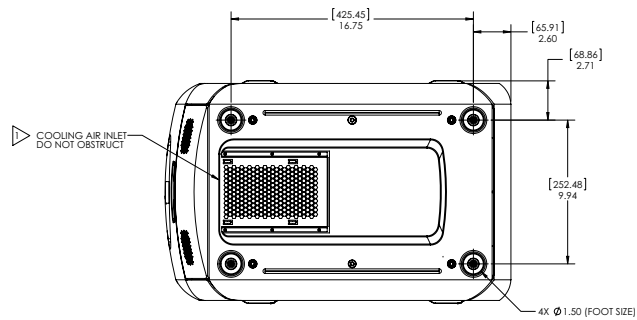
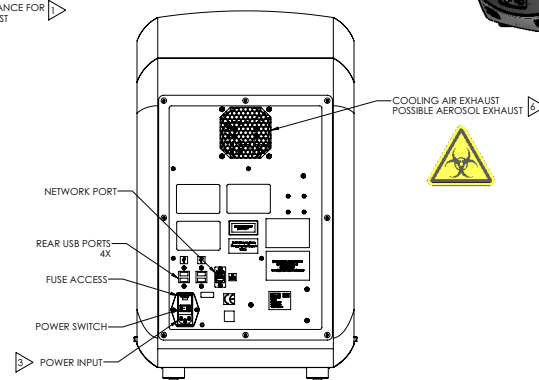
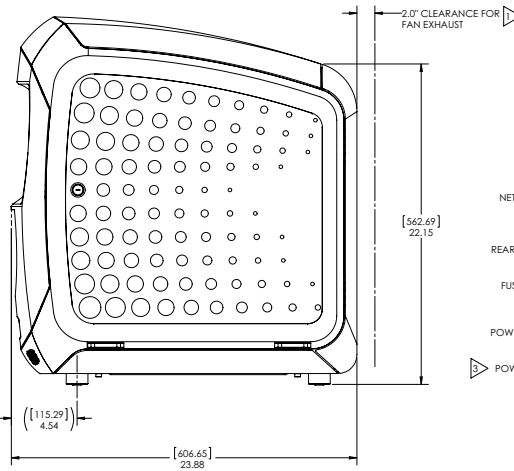
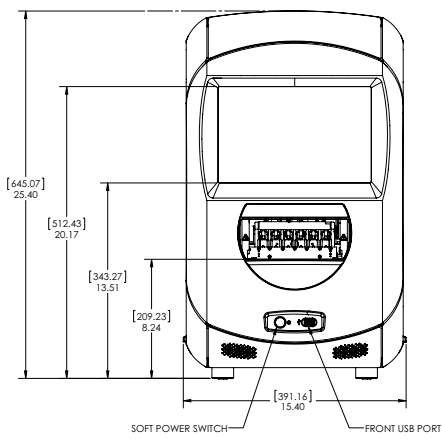
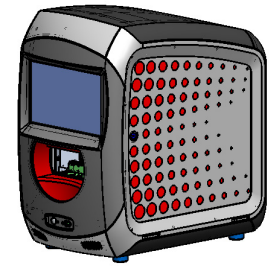

REV.	ECO NO.	INCORP BY	DATE
A	ECO-11178	S. COLL	2016/02/26
		P. SOBELTS	2016/02/26
		F. FUSSELL	2016/02/26
		F. DOHNE	2016/02/26

Luminex

DIAGRAM,
INSTALLATION,
ARIES M6V1

89-00030-00-156 A

Chapter 6: Operating Instructions

Initializing the ARIES® M1 System

To turn on the ARIES® M1 System:

NOTE: Ensure that the magazine is inserted into the instrument before beginning the initialization.

1. Flip the power switch to the **On** position at the back of the instrument.



2. Push the power button located at the front of the instrument. Powering up the ARIES® M1 System may take a few minutes.



ARIES® M1 System Status Screen

The ARIES® M1 System status screen is the first screen that displays once the instrument is powered up. See Figure 6, “*Status Screen*”. It displays the status of the module, the display run time (visible during a run), and the name of the instrument (which is customizable). The ARIES® M1 System status screen is intended to be visible from across the room, which allows you to monitor your runs while you are working on other projects.

To continue to the **Login** screen, touch or click anywhere within the ARIES[®] M1 System status screen.

FIGURE 6. **Status Screen**

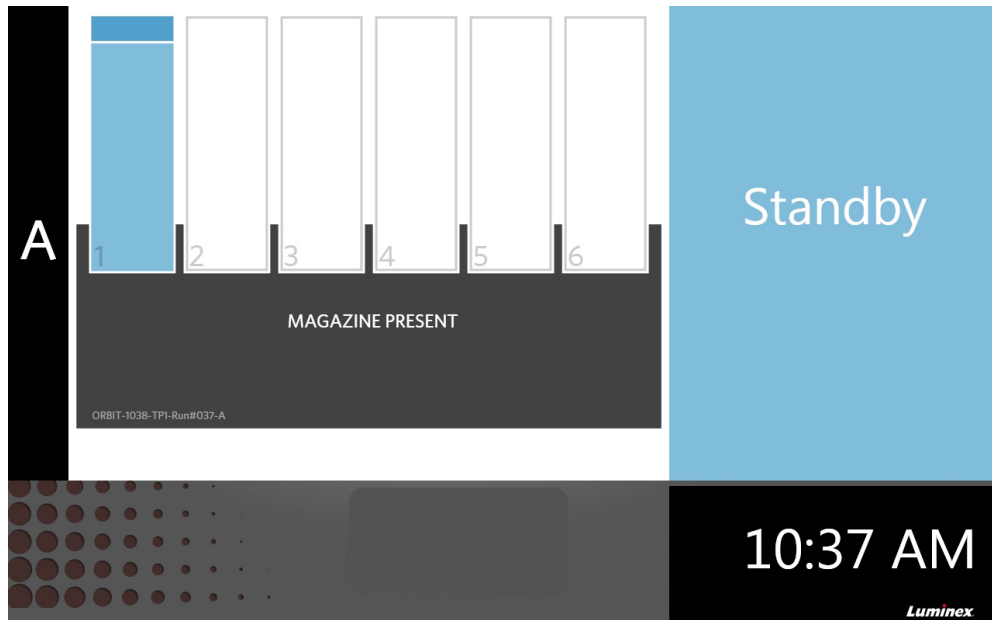

Logging into the ARIES[®] M1 System

For the initial login into the ARIES[®] M1 System, users are given a default user name and password.

	<p>TIP: You can view your password for correctness before logging in by selecting the eye icon next to the Password field. The eye icon can be activated or deactivated by the administrator on the Security Settings page. See “<i>Changing the Password Settings</i>” on page 65 for more information.</p>
--	---

1. Enter your **User name**.
2. Enter your **Password**.
3. Select **Login**.

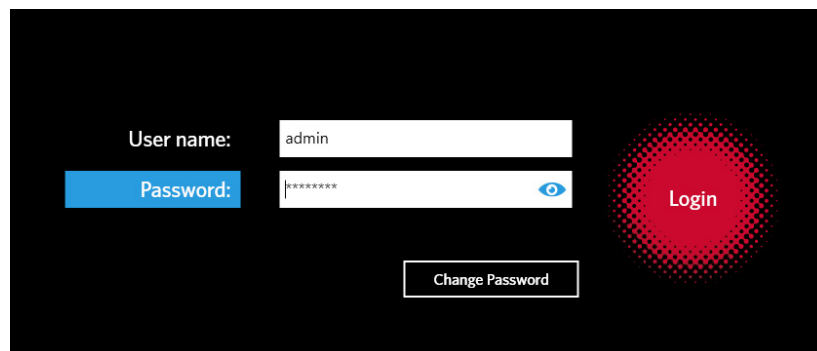

Logging into the ARIES® M1 System using your ID Badge

The ARIES® M1 System gives users the option to log in using their ID badge or other barcode (as configured by the administrator). The administrator sets up this feature for each user and ensures that the correct barcode is assigned to the user. See “*Creating Users*” on page 61 for more information.

To enable this option:

1. From the **System Navigation** menu, navigate to **Security > Settings**.
2. Toggle the **Allow Barcode Scan Login** to **Yes**.

If you see the icon below (circled in red) on the Login screen, then this feature is enabled. Simply scan your ID badge or other barcode with the hand-held barcode reader.

FIGURE 7. Barcode Scan Enabled

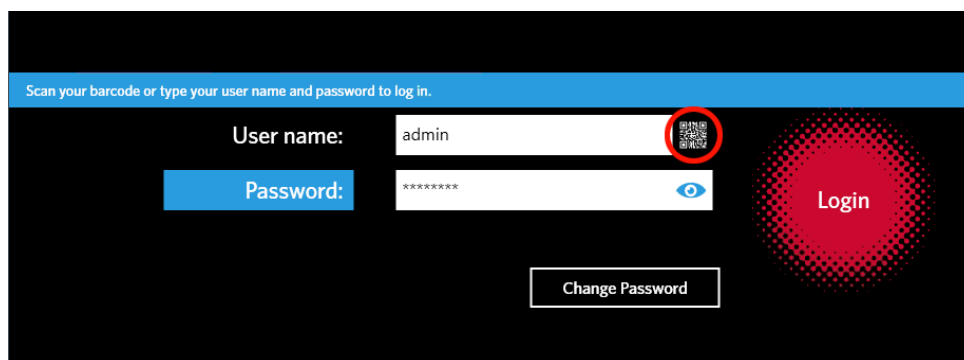

Changing your Password

Refer to “*Creating Users*” on page 61 for details on password limitations.

1. Select  from the Login screen.
2. Enter your **User name**.
3. Enter your **Old Password**.
4. Enter your **New Password**.
5. Enter your **New Password** again to verify.
6. Select **Save and Login**.

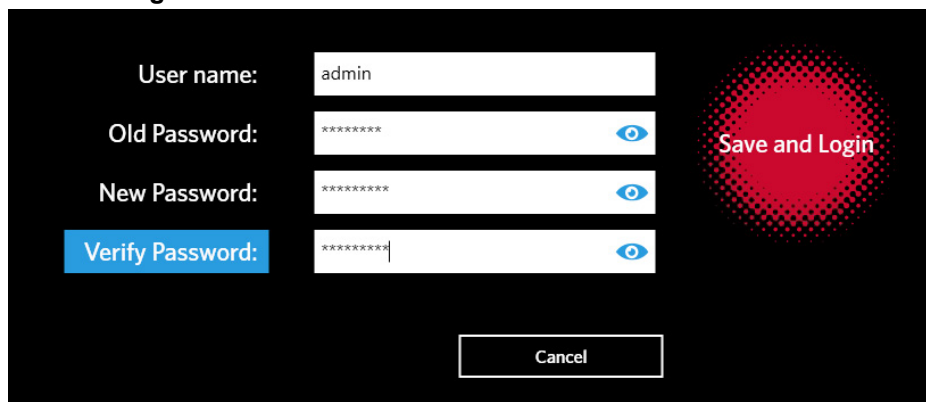

Chapter 7: Run

Run Page

The Run page allows users to view the module and each cassette individually. You can enter cassette information manually or by hand-scanning, run an assay, and add comments to each cassette if needed. The Run page also shows whether the magazine is present and what the current status is of each run (e.g., the Run page displays at what step in the run process the system is currently operating (PCR, Sample Prep, or Melt) and a countdown/estimated time to completion).

FIGURE 8. Run Page

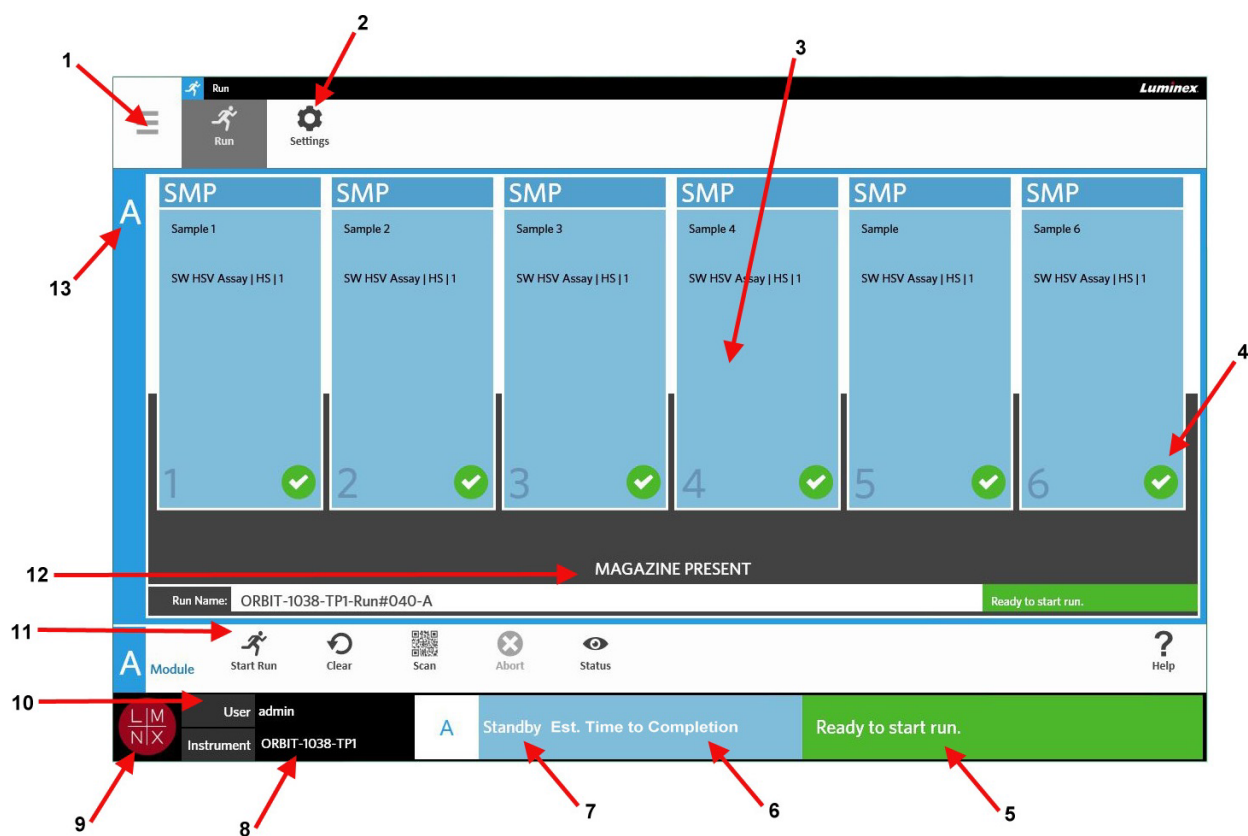

1	System Navigation button (opens the system navigation menu, see “System Navigation Menu” on page 28.)	8	Customizable instrument name
2	Application navigation bar	9	Customizable logo
3	Cassette position	10	Current user
4	Cassette status	11	Page Action bar
5	Run status	12	Magazine state
6	Display run time	13	Module A
7	Module status		

FIGURE 9. System Navigation Menu

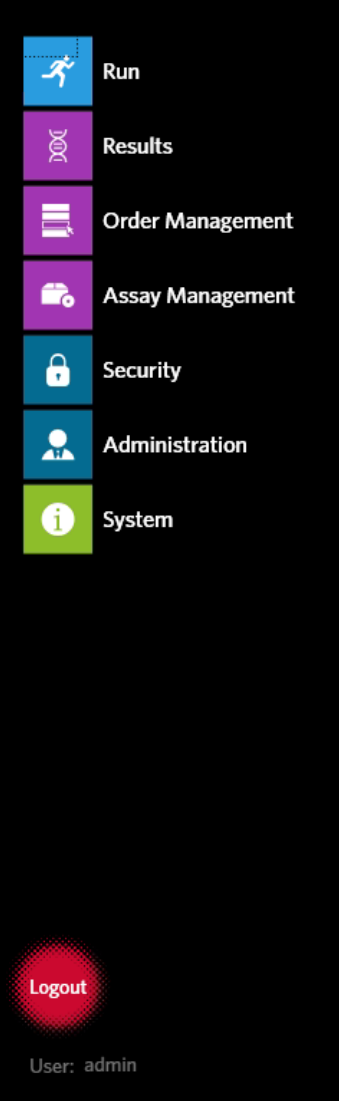

Color Definitions

The following figures define the colors used on the Run page:

FIGURE 10. **Empty Module**

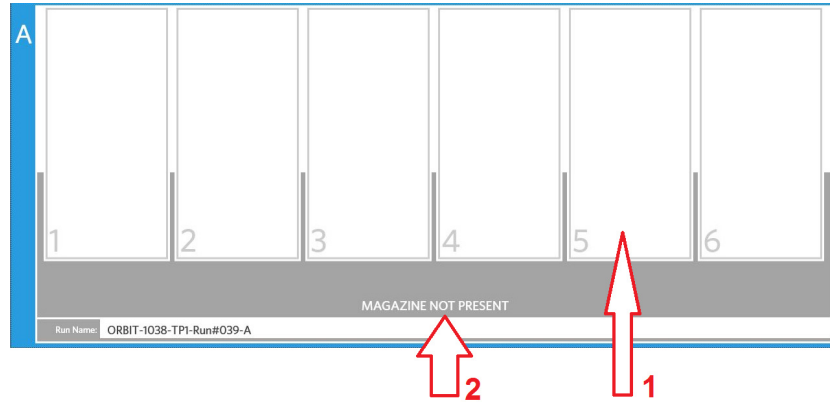

Color	Definition
1. White	Empty module, no magazine inserted or no cassette detected
2. Light Gray	Magazine not present

FIGURE 11. **Magazine Present**

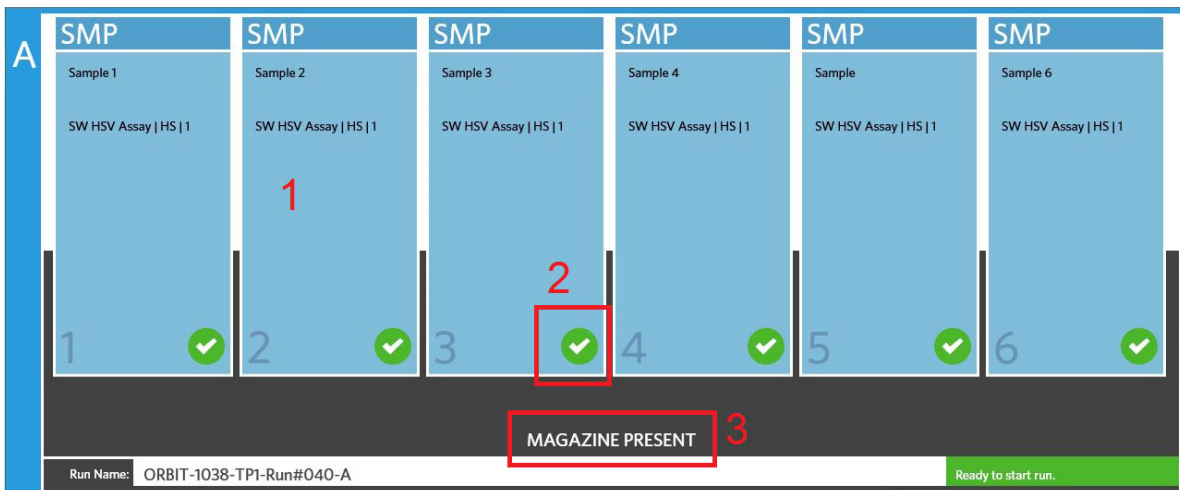

Color	Definition
1. Blue	Magazine is inserted and a cassette is detected for this slot
2. Green	Cassettes were successfully scanned with no errors
3. Dark Gray	Magazine present

FIGURE 12. Errors or Additional Information is Required

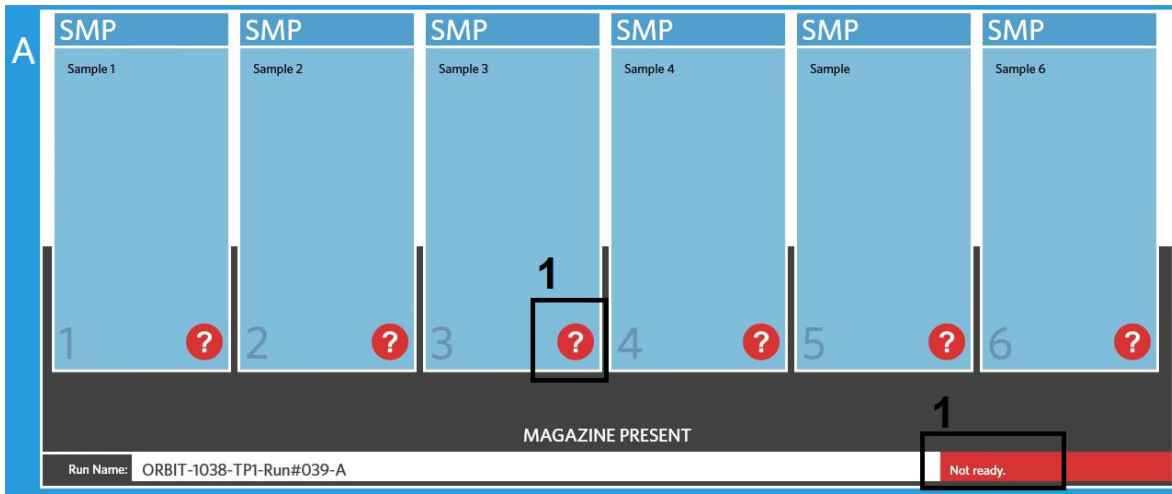

Color	Definition
1. Red	Cassettes were not scanned successfully, contain information errors, or require additional information

FIGURE 13. Run in Progress

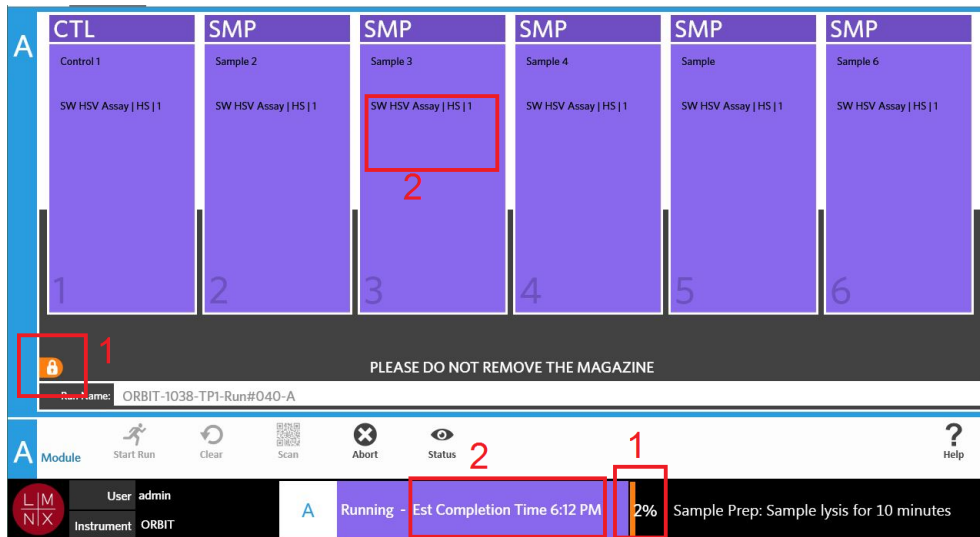

Color	Definition
1. Orange	<ul style="list-style-type: none"> Magazine is in a locked state, do not attempt to remove Run status bar
2. Purple	<ul style="list-style-type: none"> Run has started Estimated time to completion or time remaining

FIGURE 14. Manually Entered Information

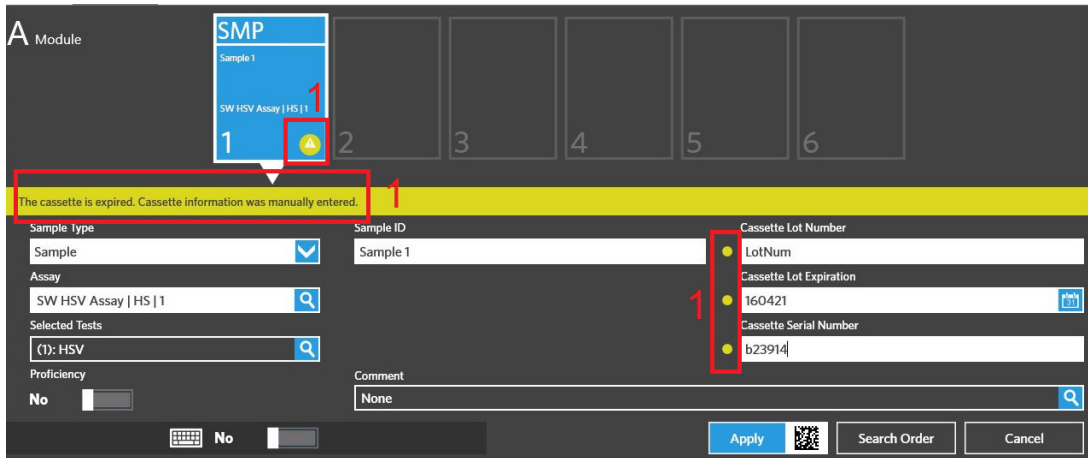

Color	Definition
1. Yellow	<ul style="list-style-type: none"> Information has been manually entered and logged to sample Cassette is expired

FIGURE 15. Run Failed or Aborted

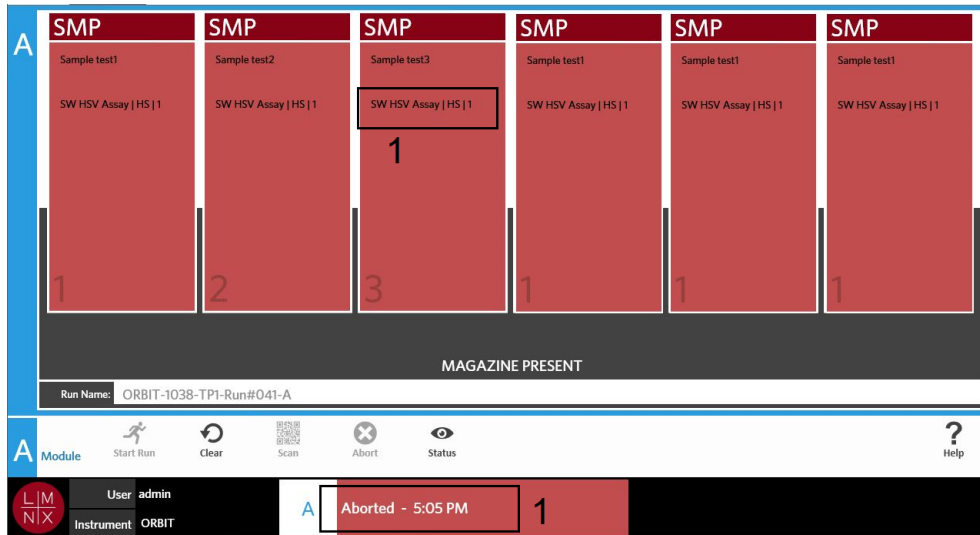

Color	Definition
1. Red	Run has failed or has been aborted

FIGURE 16. Run Completed



Color	Definition
1. Green	Run has completed successfully
2. Blue symbol	Run has an alert

FIGURE 17. Failed Control and Invalid Result

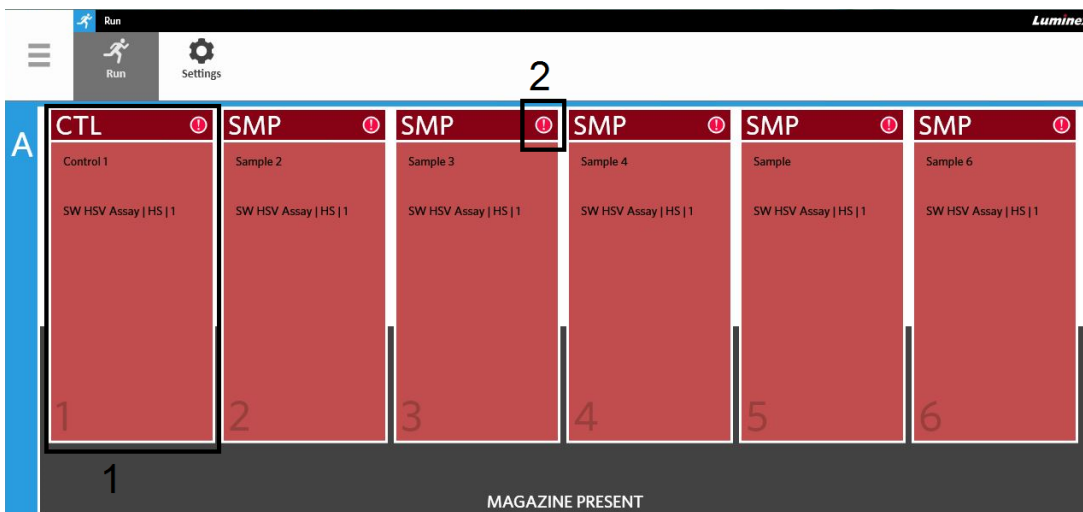

Color	Definition
1. Red	Failed control or invalid result
2. Red symbol	Failed control or invalid result

FIGURE 18. Missing Cassettes

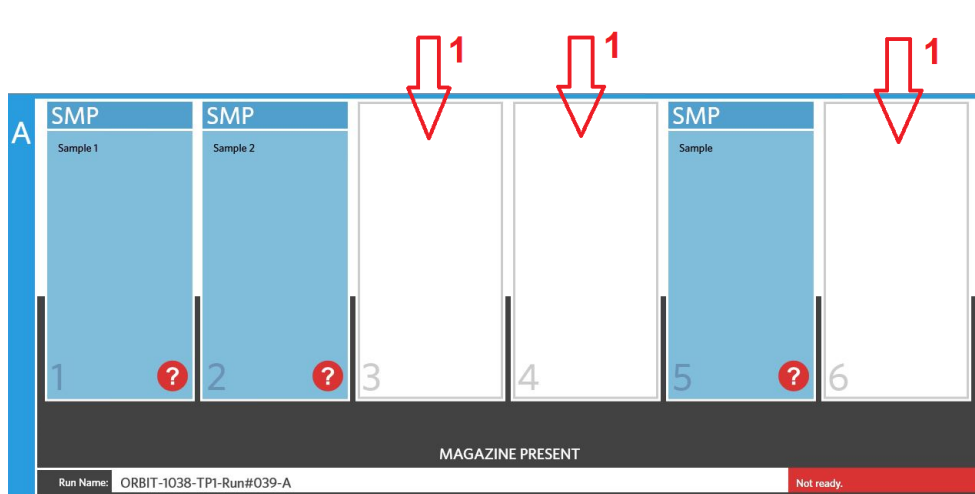



Color	Definition
1. White	Cassette is not detected for this slot

Starting a Run with Auto Run Enabled

When Auto Run is enabled, the ARIES® M1 System scans the cassettes once the magazine is inserted and automatically starts the run. To enable Auto Run, see “Enabling or Disabling Auto Run” on page 37 for more information.

NOTE: Ensure that the **Auto run upon Magazine Insertion** button is toggled to **Yes** in the **Run Options** dialog box, located on the **Run > Settings** page. The instrument automatically scans the cassettes once the magazine is inserted and starts the run.



1. Select  in the upper left-hand corner of the screen and navigate to **Run > Run**.
2. Load the samples into the cassette. Refer to the appropriate ARIES® Assay Package Insert for instructions.
3. Insert the cassettes into the magazine. See “Magazine Workflow” on page 13 for more information.
4. Insert the magazine into the ARIES® M1 System. If **Auto run upon Magazine Insertion** is enabled and no errors occur, the instrument will automatically scan and start the run for you. The magazine state then indicates **PLEASE DO NOT REMOVE THE MAGAZINE** and an orange lock icon displays on the left-hand side of the magazine state.

 **WARNING:** Do not attempt to remove the magazine after the run has started. The magazine may be hot. Removing the magazine during a run will also result in a loss of data. The cassettes cannot be reused.

Starting a Run Manually

If Auto Run is disabled, complete the following to run the assay manually:

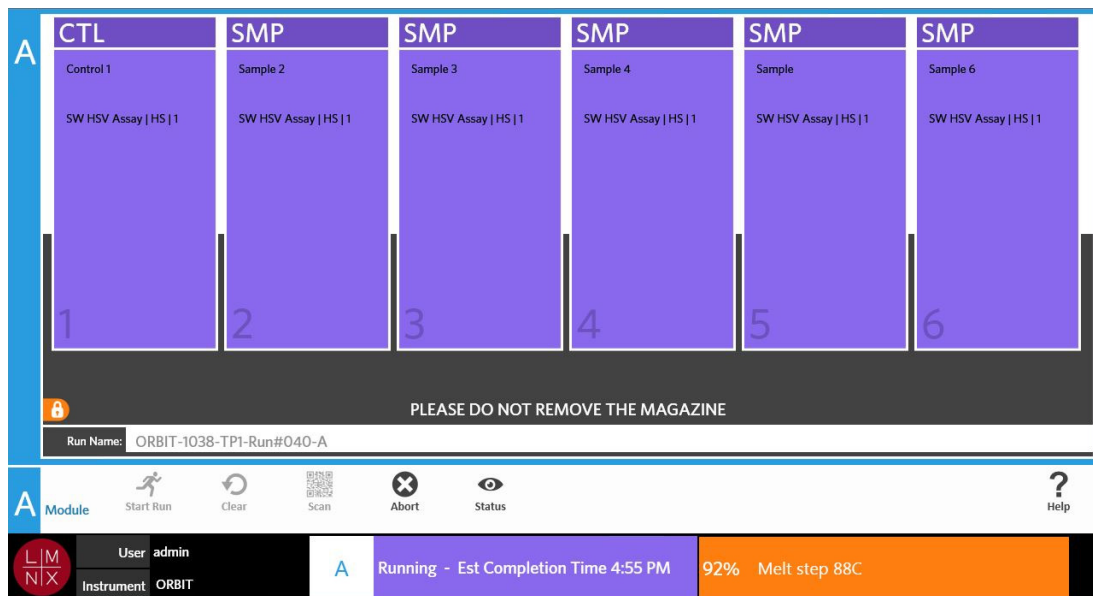

NOTE: If Auto Run is enabled, but the run did not start due to an error (e.g., missing or incorrect information), you can correct that error and select Start Run from the Page Action bar to begin the run. See “*Entering the Cassette Information Manually on the Run Page*” on page 36 for more information.

1. Select  in the upper left-hand corner of the screen and navigate to **Run > Run**.
2. Load the samples into the cassette. Refer to the appropriate ARIES® Assay Package Insert for instructions.
3. Insert the cassettes into the magazine. See “*Magazine Workflow*” on page 13 for more information.
4. Insert the magazine into the ARIES® M1 System. The magazine state indicates **MAGAZINE PRESENT** and the instrument automatically scans the cassettes.
5. Once the scan is complete and the magazine state shows **Ready to start run**, select  from the Page Action bar. The magazine state then indicates **PLEASE DO NOT REMOVE THE MAGAZINE** and an orange lock icon displays on the left-hand side of the magazine state.





Aborting a Run

	CAUTION: If you select Abort from the Page Action bar, all samples will be lost.
---	---

1. Select  in the upper left-hand corner of the screen and navigate to **Run > Run**.
2. Select  **Abort** from the Page Action bar.
3. A warning displays asking, “All samples in Module A will not be recoverable. Are you sure you want to abort the run?” Select **Yes**.

Clearing the Module

1. Select  in the upper left-hand corner of the screen and navigate to **Run > Run**.
2. Select  **Clear** from the Page Action bar. Depending on the stage of the run process the instrument is on, the following will happen:
 - If you clear the module after a scan is complete, an information dialog box will open and ask, “Information has been entered for cassettes in Module A. Are you sure you want to clear all cassettes?” Select **Yes**.
 - If you clear the module or remove the magazine after a run is complete, the module clears without a warning.

Adding a Sample Comment to a Cassette from the Run Page

NOTE: You can only add a sample comment to a cassette from the Run page if Auto run upon Magazine Insertion is disabled. To check the Auto Run settings, see “Enabling or Disabling Auto Run” on page 37 for more information.

1. After the instrument scans the cassette but before you start the run, select the cassette that needs a sample comment. The cassette information dialog box opens.
2. Select the **Comment** field and choose a comment from the **Comments** list. If you do not see the comment you need in the **Comments** list, choose **UD | User Defined Comment** from the list and enter the comment. Select **Enter** on the keyboard to save the comment when you are done.
3. Select or scan **Apply**.
4. If there are cassettes in the subsequent slots, the software automatically moves to the next slot for you to make changes. If no additional changes are needed, select **Close**.

Entering the Cassette Information Manually on the Run Page

NOTE: ARIES® M1 System does not support Unicode characters. Only ASCII characters are acceptable.

If the ARIES® M1 System successfully scans a valid barcode on the cassette, you cannot edit the cassette information from the Run page.

If the system detects a cassette but is unable to read the barcode, the system prompts you to manually enter the cassette information on the Run page before starting the run.

CAUTION: Ensure the protection of patient data by not using any patient-identifiable information (e.g., birth date, name, etc.) when entering sample information into the ARIES® M1 System. Instead, manually enter or use the barcode reader to scan the laboratory-assigned sample identifier, such as the Sample ID.

NOTE: If you enter information manually, a warning is logged to the sample. The cassette status turns yellow with a caution symbol.

The following information is required for an order to be valid:

- Sample ID
- Cassette Lot Number, Cassette Lot Expiration, and Cassette Serial Number
- Assay

1. After the system scans the cassettes and detects that the barcode is unreadable, the system prompts you to enter any additional required information.

The screenshot displays the ARIES M1 Run page interface. At the top, there are six cassette slots labeled 1 through 6. Slot 1 is highlighted with a blue box labeled 'SMP' and a red question mark icon. Below the slots, a red banner displays the message 'Sample ID must be supplied.' The main form area contains several input fields: 'Sample Type' (dropdown menu set to 'Sample'), 'Sample ID' (text field with a red 'Required' indicator), 'Cassette Lot Number' (text field), 'Assay' (text field with a search icon), 'Cassette Lot Expiration' (text field with a calendar icon), 'Selected Tests' (text field with a search icon, showing '(1): HSV'), 'Cassette Serial Number' (text field), 'Proficiency' (checkbox set to 'No'), and 'Comment' (text field with a search icon, showing 'None'). At the bottom, there are buttons for 'Apply', 'Search Order', and 'Close', along with a keyboard icon and a 'No' checkbox.

2. Enter the information needed.

NOTE: If manually entering the **Cassette Lot Expiration**, select the calendar icon and choose the date using the calendar. The date is shown in the YYMMDD format.

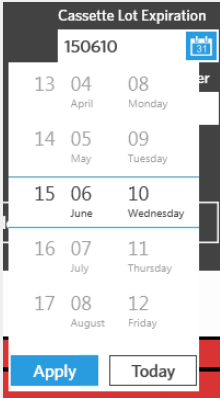

YY	MM	DD	Day
13	04	08	Monday
14	05	09	Tuesday
15	06	10	Wednesday
16	07	11	Thursday
17	08	12	Friday

3. Select or scan **Apply**.
4. If there are cassettes in the subsequent slots, the software automatically moves to the next slot for you to make changes. If no additional changes are needed, select **Close**.

Run Settings Page

In the Run Settings page, the administrator has the ability to set run options and control the module status.

FIGURE 19. Run Settings Page

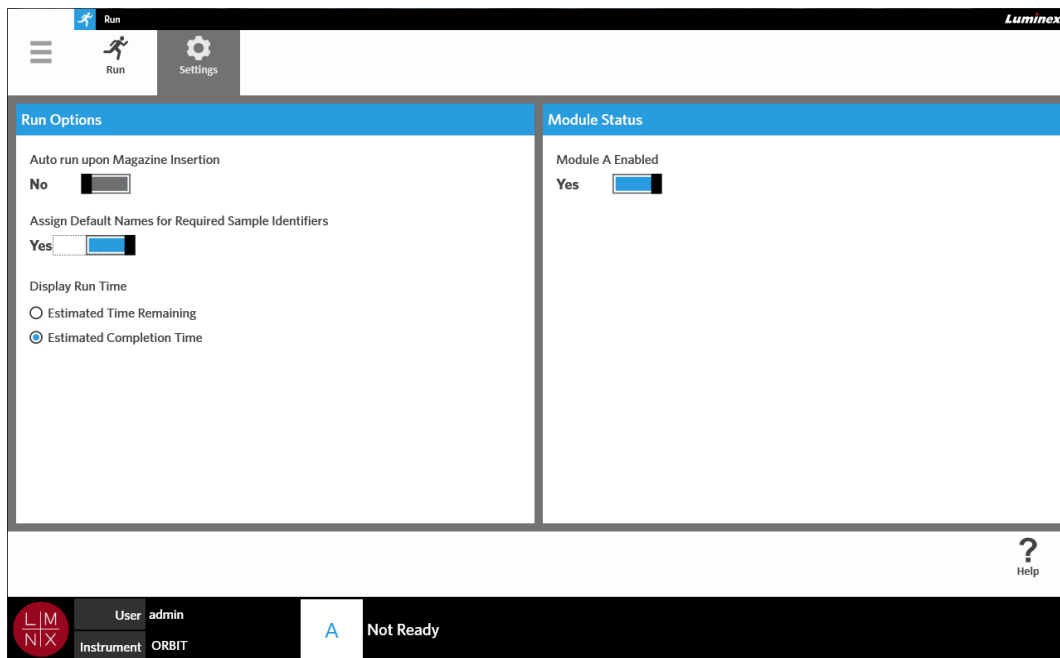

Run Options

- Auto run upon Magazine Insertion: No
- Assign Default Names for Required Sample Identifiers: Yes
- Display Run Time:
 - Estimated Time Remaining
 - Estimated Completion Time

Module Status

- Module A Enabled: Yes

User: admin
Instrument: ORBIT
Status: A Not Ready

Enabling or Disabling Auto Run

To enable or disable Auto Run, complete the following:

1. Select  in the upper left-hand corner of the screen and navigate to **Run > Settings**.
2. Toggle the **Auto run upon Magazine Insertion** button to **Yes** or **No**.

Assigning Default Names for Required Sample Identifiers to Cassettes

A default name is only assigned on the Run page if there is not a predefined order that matches the scanned cassette.

To assign default names, complete the following:

1. Select  in the upper left-hand corner of the screen and navigate to **Run > Settings**.
2. Toggle the **Assign Default Names for Required Sample Identifiers** button to **Yes**.

NOTE: If the **Assign Default Names for Required Sample Identifiers** button is toggled to **Yes**, then the Sample ID is auto-filled (e.g., Sample 1, Sample 2). If it is toggled to **No**, then you need to supply the Sample ID. In addition, if the Accession ID and Requisition Number are set as required, these values are also auto-filled.

Setting the Display Run Time

The Run Time can be displayed in two different ways on the Run and Status page. You have a choice between the Estimated Time Remaining or the Estimated Completion Time. The Estimated Time Remaining is a countdown to completion. The Estimated Completion Time is the time of completion.

To set the Run Time, complete the following:

1. Select  in the upper left-hand corner of the screen and navigate to **Run > Settings**.
2. Under **Display Run Time**, select the radio button next to **Estimated Time Remaining** or **Estimated Completion Time**.

Enabling or Disabling the Module

The Module Status feature allows you to enable or disable the module. Situations where disabling the module may be necessary are, for example, in the event that the module is pending maintenance and/or the user is instructed to disable the module by Technical Support.

To enable or disable the module, complete the following:

1. Select  in the upper left-hand corner of the screen and navigate to **Run > Settings**.

2. Toggle the **Module A Enabled** button to **Yes** or **No**. If you select **No**, a dialog box opens asking, “*Are you sure you want to disable Module A?*” You have the option to leave a comment here if needed. Select **Yes**.

NOTE: The module cannot be disabled if a run is in progress. The toggle button will not be available.

3. Navigate to the **Run** page and check the magazine state to ensure the module is enabled or disabled.

Chapter 8: Results

Results Page

The Results page contains the results of each run. You can export, filter, generate result reports, group by run or sample, and also add comments to each result. The Results page has several options to view reports and the details of each run.

FIGURE 20. Results Page

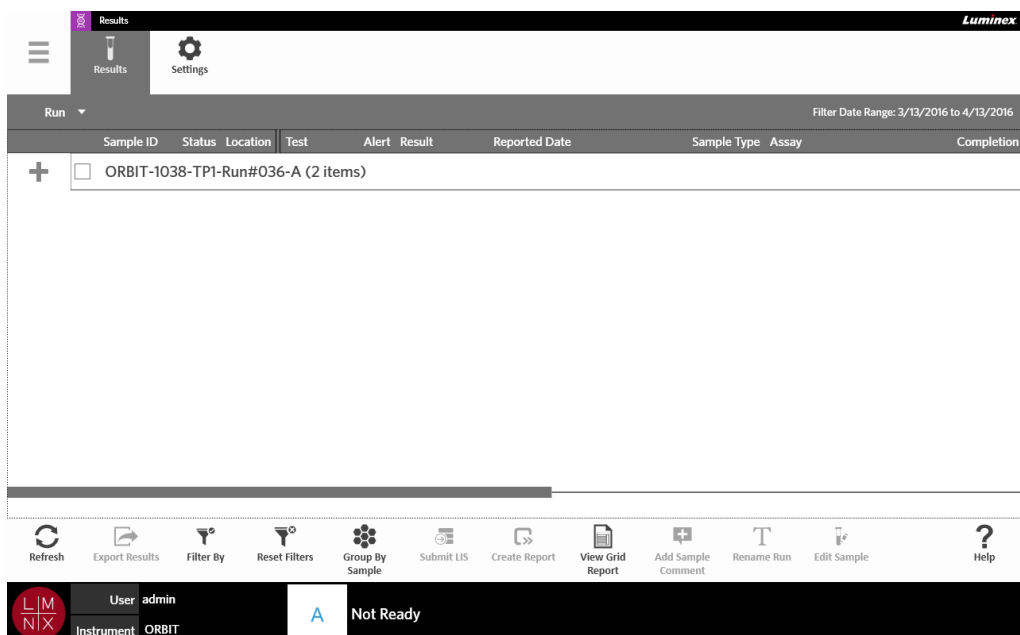

Viewing Results

1. Select  in the upper left-hand corner of the screen and navigate to **Results > Results**.
2. Select the plus sign (+) next to the run to expand the run details of each cassette.



TIP: You can change the view of this page by selecting **Group By Sample** from the Page Action bar. **Group By Sample** changes the view to sort the results by sample instead of by run.

Creating a Report

1. Select  in the upper left-hand corner of the screen and navigate to **Results > Results**.
2. Select the plus sign (+) next to the run to expand the run details of each cassette.

3. Select the result that you want to view in a report.

NOTE: You can select multiple results from the same run and still use the **Create Report** icon to generate a “Run Report”. The **Create Report** icon is disabled only when results from multiple runs are selected.

4. Select  from the Page Action bar.
5. Choose the type of report from the drop-down menu. Once the report generates, you have a choice of exporting or printing the report.

6. Select  from the Page Action bar.

Exporting Results

The Exporting Results function exports a CSV file to the designated location. This is one CSV file that contains all results that were selected on the page. It does not export individual CSV files for each result. The Exporting Results function does not export a PDF of the results.



1. Select  in the upper left-hand corner of the screen and navigate to **Results > Results**.
2. Select the plus sign (+) next to the run to expand the run details of each cassette.
3. Select the result(s) to export.

4. Select  from the Page Action bar. The **Export File** dialog box opens.
 - a. Choose the **Location** for the export.
 - b. Select **OK**.

Filtering Results





The default filter is set to one month prior to the current date. Filters will revert back to the default settings each time you select Filter By from the Page Action bar. To keep filters from reverting back to the default settings, you must enable Persist Filters. To enable Persist Filters, see “*Enabling Persist Filters*” on page 85 for more information.

To change the filter, complete the following:

1. Select  in the upper left-hand corner of the screen and navigate to **Results > Results**.
2. Select  from the Page Action bar. The **Filter By** dialog box opens.
3. Choose the filter you want to use. The options are:
 - **Run Name**
 - **Sample ID**
 - **Assay**

- Accession ID
 - User
 - Sample Comment
 - Requisition Number
 - Test Name
 - Result
 - Module ID
 - Lot Number
 - Status
 - Instrument ID
 - Time Range
 - Date From and Date To
 - Sample Type
 - Proficiency Only
4. Select **Apply**.

Grouping by Run or Grouping by Sample



1. Select  in the upper left-hand corner of the screen and navigate to **Results > Results**.
2. Select  from the Page Action bar to toggle between  **Group By Run** or  **Group By Sample**. This is one button that changes when selected and depending on how the icon is toggled, the page will display the samples for each run grouped together or list all samples individually.

Resetting Filters

To reset your filters and go back to the default view, select  **Reset Filters** from the Page Action bar.

Adding a Sample Comment to a Result from the Results Page

NOTE: You cannot remove a comment from a result once it is added. If an error is made, you can create a new comment or select another comment from the list.



1. Select  in the upper left-hand corner of the screen and navigate to **Results > Results**.
2. Select the plus sign (+) next to the run to expand the run details of each cassette.
3. Select the result to add a comment.
4. Select  **Add Sample Comment** from the Page Action bar. The **Comments** dialog box opens.
5. Choose a comment from the **Comments** list. If you do not see the comment you need in the **Comments** list, choose **UD | User Defined Comment** from the list and enter the comment. Select **Enter** on the keyboard when you are done.

Submitting to the LIS



The Submit LIS feature allows you to resubmit a result to the LIS in the event any changes were made to the result (e.g., if you changed the run name, added a comment, or used the Edit Sample feature). See “Automatically Exporting to LIS” on page 75 to enable the LIS and set up the export location.

NOTE: Validation of the LIS compatibility must be performed by the user.

To submit the results to the LIS, complete the following:

1. Select  in the upper left-hand corner of the screen and navigate to **Administration > LIS Settings**.
2. Ensure that the **Enable Export To LIS** button is toggled to **Yes** and the **LIS Export Location** is specified.
3. Select  in the upper left-hand corner of the screen and navigate to **Results > Results**.
4. Select the plus sign (+) next to the run to select an individual result or select the run that you want to resubmit.
5. Select  from the Page Action bar.

Renaming a Run

1. Select  in the upper left-hand corner of the screen and navigate to **Results > Results**.
2. Select the run.
3. Select  from the Page Action bar.
4. Enter the new run name in the field provided.
5. Select **OK**.

Editing a Sample

Editing a sample allows you to edit the sample identifiers (Sample ID, Accession ID, or Requisition Number) and the selected tests for that sample.

CAUTION: Ensure the protection of patient data by not using any patient-identifiable information (e.g., birth date, name, etc.) when entering sample information into the ARIES® M1 System. Instead, manually enter or use the barcode reader to scan the laboratory-assigned sample identifier, such as the Sample ID.

To edit a sample, complete the following:

1. Select  in the upper left-hand corner of the screen and navigate to **Results > Results**.
2. Select the plus sign (+) next to the run to expand the run details of each cassette.
3. Select the sample from the **Results** page that needs editing.

4. Select  **Edit Sample** from the Page Action bar.
5. Edit the sample identifiers (**Sample ID**, **Accession ID**, or **Requisition Number**) or update the **Selected Tests** as needed. Certain permissions may be required to update the selected tests for a sample.
 - a. Select the **Selected Tests** field. The **Test Selection** dialog box opens.
 - b. To unmask a test, choose **Selected**.

NOTE: When editing a sample on the Results page, users can only select tests; tests cannot be masked after the sample has been acquired.

- c. Select **Close**.
6. Select or scan **OK**.

Generating a Grid Report

The Grid Report is a PDF view of the content on the page. Select  **View Grid Report** from the Page Action bar to generate a PDF. When the **Preview** page opens with the generated PDF, print and/or export the Grid Report if needed.

Results Settings Page

The Results Settings page is where you can choose how and where to automatically export and print the reports. Reports can only be exported to a network drive or to a USB drive. To set default reports, see “*Setting up Report and Graph Options*” on page 57 for more information.

NOTE: Luminex recommends automatically exporting only to a network drive, as a USB drive can accidentally be removed and cause an error to occur during export.

FIGURE 21. Results Settings Page

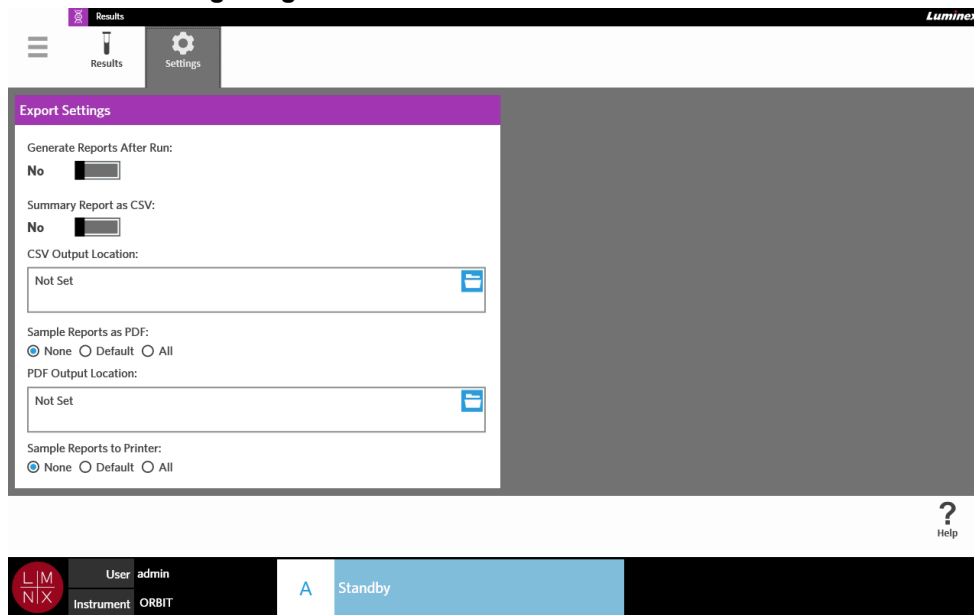

Generating Reports After a Run

The Generate Reports After Run toggle button, in the Export Settings dialog box, is a turn on switch for the export options. If the Generate Reports After Run button is toggled to No, then none of the export settings in this dialog box will be functional.

To generate reports after a run,

1. navigate to **Results > Settings**.
2. toggle the **Generate Reports After Run** button to **Yes**.

Setting Up to Automatically Export a Summary Report as CSV

The Summary Report as CSV feature exports a CSV file to a designated output location. This file is the same CSV that can be manually exported from the Results page. See “Exporting Results” on page 41 for more information.

NOTE: Ensure that the Generate Reports After Run button is toggled to Yes in the Export Settings dialog box. If the Generate Reports After Run button is toggled to No, then none of the export settings in this dialog box will be functional.

To export results automatically after a run, complete the following:

1. Select  in the upper left-hand corner of the screen and navigate to **Results > Settings**.
2. Toggle the **Summary Report as CSV** button to **Yes**.
3. Enter the **CSV Output Location** by selecting the folder icon in the upper right-hand corner of the **CSV Output Location** box. The **Select Folder** dialog box opens.
 - a. Choose the **Location** for the export.

- b. Select **OK**.

Setting Up to Automatically Export a Sample Report as PDF

The Sample Reports as PDF feature exports a PDF to a designated output location.

NOTE: Ensure that the Generate Reports After Run button is toggled to Yes in the Export Settings dialog box. If the Generate Reports After Run button is toggled to No, then none of the export settings in this dialog box will be functional.

To export a Sample Report automatically after a run, complete the following:

1. Select  in the upper left-hand corner of the screen and navigate to **Results > Settings**.
2. Select the **Default** or **All** radio button. If you choose **Default**, then only the reports set to default on the **Assay Management** page will export to the output location. To set up default reports, see “*Setting up Report and Graph Options*” on page 57 for more information. If you choose **All**, then all reports export to the output location.
3. Enter the **PDF Output Location** by selecting the folder icon in the upper right-hand corner of the **PDF Output Location** box. The **Select Folder** dialog box opens.
 - a. Choose the **Location** for the export.
 - b. Select **OK**.

Setting Up to Automatically Print Sample Reports After a Run is Complete

The Sample Reports to Printer feature sends reports to the printer automatically after a run is complete.

NOTE: Ensure that the Generate Reports After Run button is toggled to Yes in the Export Settings dialog box. If the Generate Reports After Run button is toggled to No, then none of the export settings in this dialog box will be functional.

To send sample reports to the printer automatically after a run, complete the following:

1. Select  in the upper left-hand corner of the screen and navigate to **Results > Settings**.
2. Under **Sample Reports to Printer**, select the **Default** or **All** radio button. If you choose **Default**, then only the reports set to default on the **Assay Management** page are sent to the printer. If you choose **All**, then all reports are sent to the printer.

Chapter 9: Order Management

Sample Orders Page

The Sample Orders page allows you to create, edit, import, delete, and export orders.

CAUTION: Ensure the protection of patient data by not using any patient-identifiable information (e.g., birth date, name, etc.) when entering sample information into the ARIES® M1 System. Instead, manually enter or use the barcode reader to scan the laboratory-assigned sample identifier, such as the Sample ID.

FIGURE 22. Sample Orders Page

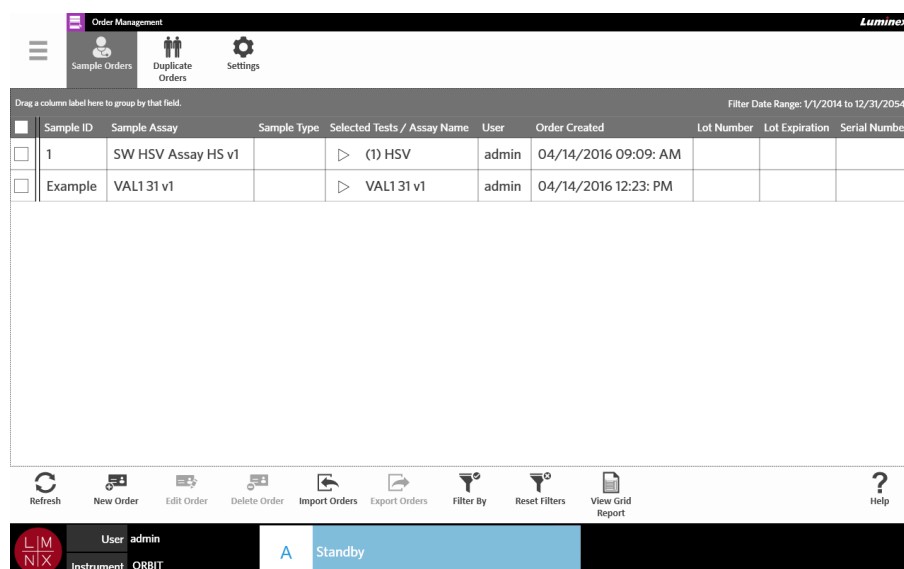



Associating Cassettes to Samples

Each cassette must be associated with a specific sample. The Sample ID is required on all orders and is the link between sample and cassette. The Accession ID and Requisition Number can also perform this role and associate the cassette to the sample, but are optional unless otherwise chosen to be required by you. You can set requirement options in the Sample Options dialog box located on the Order Management Settings page. When the magazine containing the samples is inserted into the ARIES® instrument, the instrument will automatically recognize the cassette, assay type, and sample by scanning the unique cassette barcode.

Creating a New Order

At a minimum, the Sample ID and Assay are required for an order to be valid.

NOTE: The order should be created prior to placing the cassette in the magazine. If you scan the cassette while the cassette is in the magazine, it is possible to scan the incorrect cassette barcode.

1. Select  in the upper left-hand corner of the screen and navigate to **Order Management > Sample Orders**.
2. Select  from the Page Action bar.
3. Pick up and scan the cassette with the hand-held barcode reader or enter the required cassette information manually.

NOTE: If manually entering the **Cassette Lot Expiration**, select the calendar icon and choose the date using the calendar. The date is shown in the YYMMDD format.

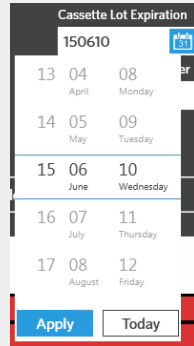

4. Pick up and scan or enter the **Sample ID**.
5. Optionally, select the **Selected Tests** field. The **Test Selection** dialog box opens.
 - a. Choose **Selected** or **Masked** for each test shown. Reports and results will not include data for any masked tests.



NOTE: At least one test must remain unmasked. You cannot mask all tests.

- b. Select **Close**.
6. Select or scan **Save**.

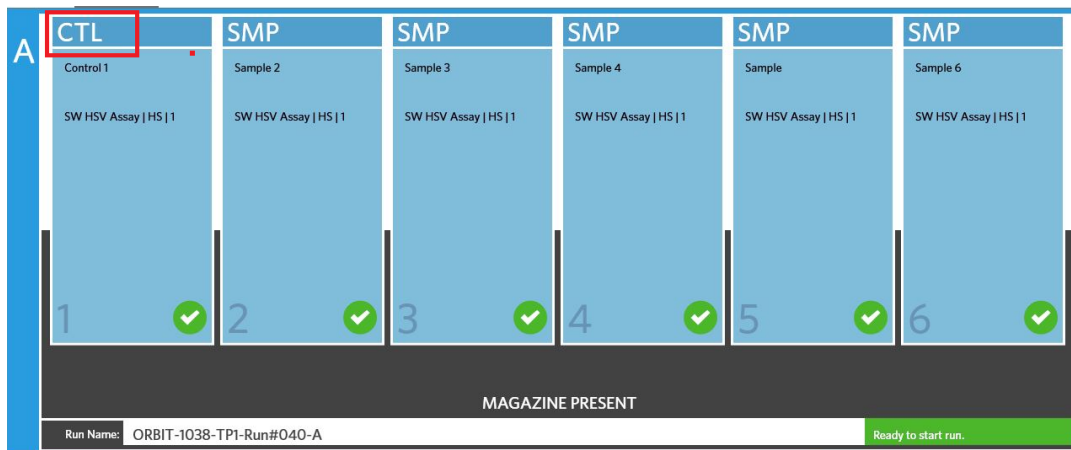

Creating a Control Order

FIGURE 23. Control Order on the Run Page



1. Create a **Control Lot** before creating a control order, see “*Creating a Control Lot*” on page 58 for instructions.
2. Select  in the upper left-hand corner of the screen and navigate to **Order Management > Sample Orders**.
3. Select  from the Page Action bar.
4. In the **Sample Type** drop-down menu, choose **Control**.
5. Select the **Assay** field and scan the cassette or choose an assay from the list.
6. Select the **Control** field and choose the pre-defined Control.
7. In the **Control Type** drop-down menu, choose the **Control Type** from the list. The options are:
 - **Run** - Run control
 - **Wipe** - Environmental wipe of equipment or area to test for contamination
 - **Lot Check** - Sample being tested from new lot receipt
 - **Training** - Sample being used for new operator training
 - **Other**
8. Select or scan **Save**.



Editing an Order

1. Select  in the upper left-hand corner of the screen and navigate to **Order Management > Sample Orders**.
2. Select the order you want to edit.
3. Select  from the Page Action bar.
4. Edit the order as needed.
5. Select or scan **Save**.

Importing Orders



CSV files that were created and exported from one ARIES[®] M1 System can be imported onto a different ARIES[®] M1 System or the ARIES[®] System.

NOTE: Be aware that if importing orders from another instrument, the destination instrument must contain the assay files required by the order. If the assay files are not installed, the orders will not import.



1. Select  in the upper left-hand corner of the screen and navigate to **Order Management > Sample Orders**.
2. Select  from the Page Action bar. The **Import File** dialog box opens.
 - a. Choose the **Location** and **File Name** for the import.
 - b. Select **OK**.

Exporting Orders

CSV files can be exported from the ARIES® M1 System and imported onto a different ARIES® M1 System or the ARIES® System.

1. Select  in the upper left-hand corner of the screen and navigate to **Order Management > Sample Orders**.
2. Select the order(s) to export.
3. Select  from the Page Action bar. The **Export File** dialog box opens.
 - a. Choose the **Location** for the export.
 - b. Select **OK**.



Deleting Orders

1. Select  in the upper left-hand corner of the screen and navigate to **Order Management > Sample Orders**.
2. Select the order(s) to delete.
3. Select  from the Page Action bar.
4. A dialog box displays asking, “Are you sure you want to delete the order?” Select **Yes**.

NOTE: Once the order is deleted, this action cannot be undone.

Filtering Orders

Filters will revert back to default settings each time you select Filter By from the Page Action bar. To keep filters from reverting back to the default settings, you must enable Persist Filters. To enable Persist Filters, see “Enabling Persist Filters” on page 85 for more information.

1. Select  in the upper left-hand corner of the screen and navigate to **Order Management > Sample Orders**.
2. Select the  from the Page Action bar. The **Filter By** dialog box opens.
3. Choose the type of filter you want to use. The options are:
 - **LIS Only**
 - **Sample ID**
 - **Accession ID**
 - **Requisition Number**
 - **Assay**
 - **User**

- **Sample Type**
- **Time Range**
- **Date From and Date To**

4. Select **OK**.

Resetting Filters



To reset your filters and return to the default view, select **Reset Filters** from the Page Action bar.

Generating a Grid Report



The Grid Report is a PDF view of the content on the page. Select **View Grid Report** from the Page Action bar to generate a PDF. When the **Preview** page opens with the generated PDF, print and/or export the Grid Report if needed.

Duplicate Orders Page

There are two instances where the ARIES® M1 System may flag an order as a duplicate. You will know if a duplicate order is detected if they see the following color change and indicator on the application bar:

FIGURE 24. Duplicate Orders Indicator

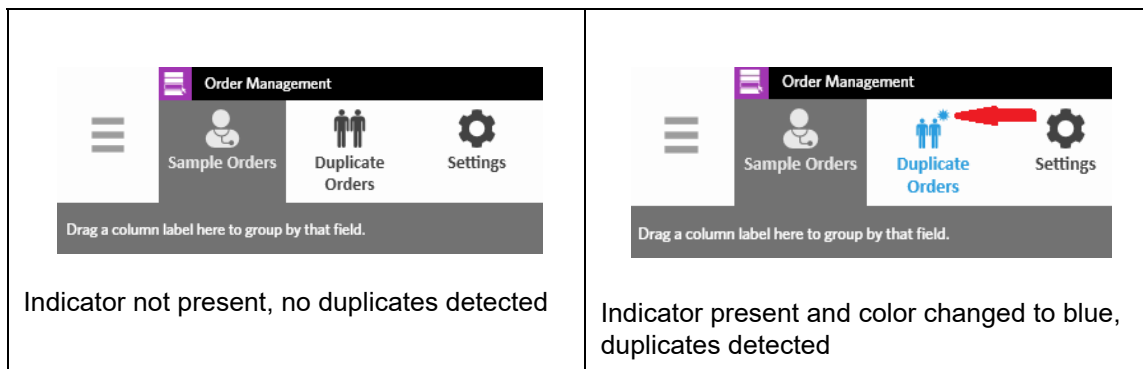

- The first instance where the system may flag an order is if two or more orders have matching Sample IDs, Accession IDs, or Requisition Numbers. In this scenario, all duplicate orders are flagged. If the **Duplicate Orders** toggle button on the **Order Management Settings** page is toggled to **Yes**, the sample identifiers (Sample ID, Accession ID, and Requisition Number) are monitored on the **Sample Orders** page for duplicate information. See *“Enabling Duplicate Orders”* on page 54. You can edit or delete the duplicate orders if needed. See *“Editing a Duplicate Order”* on page 53 and *“Deleting a Duplicate Order”* on page 53 for more information.

NOTE: The orders will not be flagged as duplicates if different assays are selected.

FIGURE 25. Matching Sample Identifiers Detected

Sample ID	Accession ID	Requisition Number	Sample Assay	Sample Type	Selected Tests / Assay Name	User	Order Created	Lot Number	Lot Expiration
Example			VAL131 v1	Sample	▶ VAL131 v1	admin	04/14/2016 12:23: PM		
Example			VAL131 v1	Sample	▶ VAL131 v1	admin	04/18/2016 01:53: PM		
Example 1	123456		VAL131 v1	Sample	▶ VAL131 v1	admin	04/18/2016 01:58: PM		
Example 1	123456		VAL131 v1	Sample	▶ VAL131 v1	admin	04/18/2016 01:57: PM		

Refresh Edit Order Delete Order Apply Results ? Help

User: admin Instrument: ORBIT A Not Ready

- The second instance where the system may flag an order is if a result, for that order, already exists on the **Results** page. The system monitors the sample identifiers (Sample ID, Accession ID, and Requisition Number) and recognizes that a sample has already been run for that order. The order is flagged as a duplicate and is visible on the **Duplicate Orders** page. When this duplicate order is selected, you will notice that the **Apply Results** button on the Page Action bar becomes available to use. See “Applying Results to a Duplicate Order” on page 53 for more information.



FIGURE 26. Duplicate Order with Existing Result

Sample ID	Accession ID	Requisition Number	Sample Assay	Sample Type	Selected Tests / Assay Name	User	Order Created	Lot Number	Lot Expiration
Sample 3			Luminex_HSV_IUO IA v2	Sample	▶ (1) HSV	admin	04/30/2015		



Refresh Edit Order Delete Order Apply Results ? Help

User: admin Instrument: ORBIT A Running - Est Completion Time 5:05 PM 62% PCR Denature: 41, 93C for 5 seconds

Editing a Duplicate Order

1. Select  in the upper left-hand corner of the screen and navigate to **Order Management > Duplicate Orders**.
2. Select the order to edit.
3. Select  **Edit Order** from the Page Action bar.
4. Edit the order as needed.
5. Select or scan **Save**.



Deleting a Duplicate Order

1. Select  in the upper left-hand corner of the screen and navigate to **Order Management > Duplicate Orders**.
2. Select the order(s) to delete.
3. Select  **Delete Order** from the Page Action bar.
4. A dialog box displays asking, “Are you sure you want to delete the order?” Select **Yes**.

NOTE: Once the order is deleted, this action cannot be undone.

Applying Results to a Duplicate Order

When there is a duplicate order with an existing result on the Results page, you can apply those results to the order on the Duplicate Orders page. In addition, you can edit the sample on the Results page before applying the results to the duplicate order. For example, if the Sample ID or the Selected Tests for a result needs to be updated.

1. Select  in the upper left-hand corner of the screen and navigate to **Order Management > Duplicate Orders**.
2. If needed, edit the sample on the results page before applying results to the duplicate order. See “*Editing a Sample*” on page 43 for more information.
3. Select the duplicate order. Notice that the **Apply Results** button on the Page Action bar is now available for use.
4. Select  **Apply Results** from the Page Action bar. The **Results** dialog box opens. This dialog box contains the matching result that is located on the Results page.
5. Choose the result.
6. Select **Apply**.

NOTE: The software creates a duplicate run with the reanalyzed data, thus leaving the original sample unchanged with its original run.

7. The **Messages** dialog box opens informing you that the sample was successfully reanalyzed. Select **OK**.

Order Management Settings Page

The Order Management Settings page allows you to set the Sample Options.

FIGURE 27. **Order Management Settings Page**

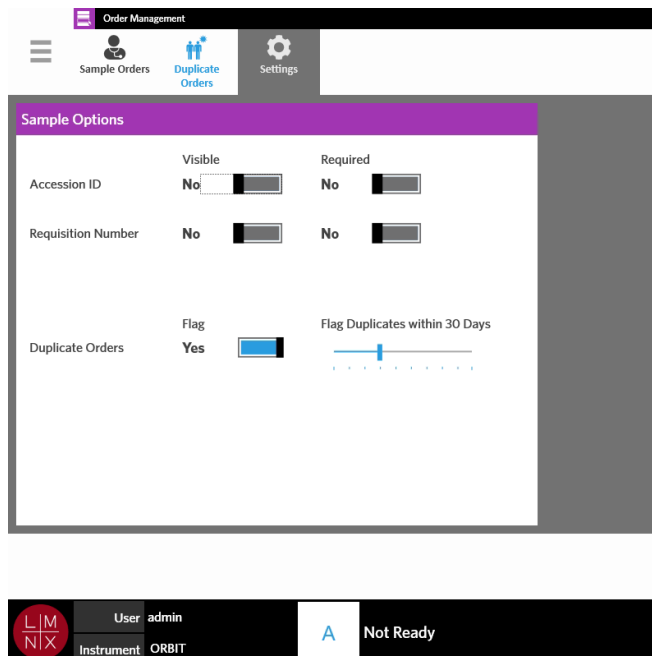

Making Sample Options Required and/or Visible for an Order

Administration rights may be required to change the Order Management Settings. Enabling these options may affect order creation. Depending on system settings, the Accession ID and Requisition Number may be automatically assigned or input manually on the Run page if a matching order is not found for a scanned cassette.

To make sample options required and/or visible on orders, complete the following:

1. Select  in the upper left-hand corner of the screen and navigate to **Order Management > Settings**.
2. In the **Sample Options** dialog box, ensure that the following buttons are toggled to **Yes** if you want them to be required and/or visible:
 - **Accession ID**
 - **Requisition Number**

Enabling Duplicate Orders

To enable Duplicate Orders, complete the following:

1. Select  in the upper left-hand corner of the screen and navigate to **Order Management > Settings**.
2. In the **Sample Options** dialog box, ensure that the **Duplicate Orders** button is toggled to **Yes**.
3. Select and hold the **Flag Duplicates within X Days** slide bar and slide to the desired number of days.

Chapter 10: Assay Management

Assay Management Page

The Assay Management page allows you to import, view, and delete assays as well as set assay options.

FIGURE 28. Assay Management Page

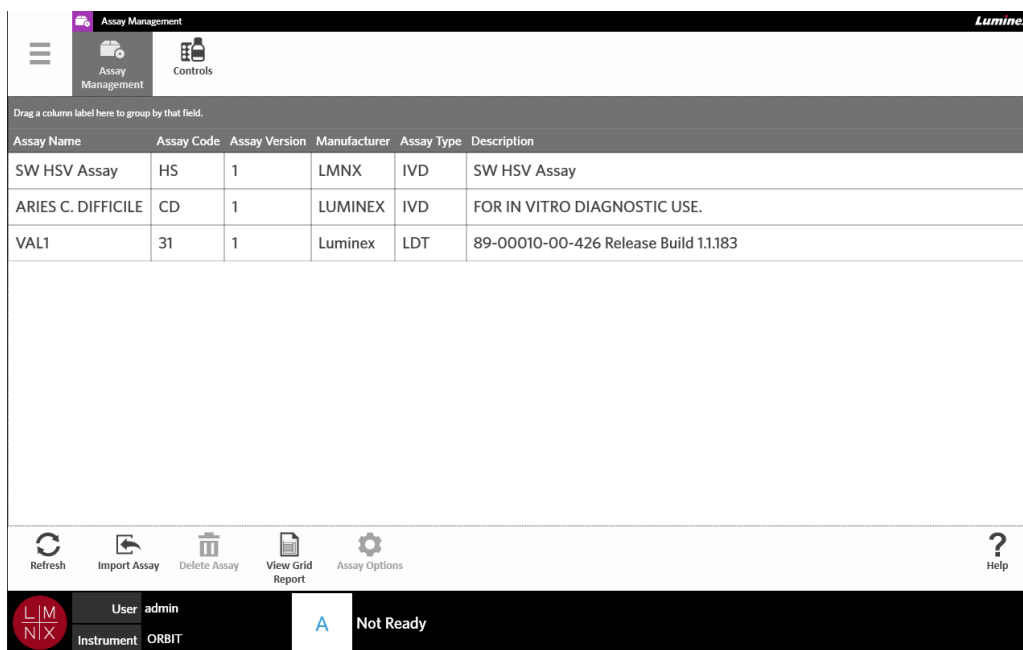



Importing Assay Files to the ARIES® M1 System

The ARIES® M1 System is shipped without assay files loaded onto the system. You will need to import the assay files once the instrument is installed. The files are located on the USB flash drive provided with the first order of each assay.

WARNING: The USB flash drive is for installing assay files only. Do not use the USB flash drive for anything other than its intended purpose. Do not plug any external electronic devices into the ARIES® M1 System other than those provided by Luminox.

To import the assay files, complete the following:

1. Insert the USB flash drive into one of the five USB connectors (one in the front and four in the back).
2. Select  in the upper left-hand corner of the screen and navigate to **Assay Management > Assay Management**.
3. Select  from the Page Action bar. The **Import File** dialog box opens.
 - a. Choose the **Location** and **File Name** of the assay file.
 - b. Select **OK**.

Deleting an Assay

1. Select  in the upper left-hand corner of the screen and navigate to **Assay Management > Assay Management**.
2. Select the assay to delete.

3. Select  from the Page Action bar.
4. A dialog box displays asking, “*You are about to delete an Assay. Do you want to continue?*” Select **Yes** or **No**.

Setting up Report and Graph Options

The report and graph options are unique for each assay loaded onto the system. Some report types may be security-restricted and accessible only to users with administration rights.

Report Options

The default report selected for each assay will be the report that prints/saves to PDF if Default is selected on the Results Settings page. See the “*Results Settings Page*” on page 44 to view the export settings.

1. Select  in the upper left-hand corner of the screen and navigate to **Assay Management > Assay Management**.
2. Select an assay.

3. Select  from the Page Action bar.
4. To select the default report for that assay, toggle the **Is Default Report** button to **Yes** or **No**.
5. Select **Save Changes**.
6. The **Messages** dialog box opens informing you that options for the assay have been modified. Select **OK**.

Graph Options

ARIES® chemistry records a decrease in fluorescence, resulting in a downward-sloping graph. Users who are more familiar with the increasing fluorescence of alternate chemistries may prefer to invert the y-axis of the graph to display an upward-sloping curve. Inversion of the curve does not affect data; it is simply a graphical preference.

1. Select  in the upper left-hand corner of the screen and navigate to **Assay Management > Assay Management**.
2. Select an assay.

3. Select  from the Page Action bar.
4. Under **Graph Options**, toggle **Invert PCR Graph** and **Invert Melt Graph** to **Yes** or **No**.

5. Select **Save Changes**.
6. The **Messages** dialog box opens informing you that options for the assay have been modified. Select **OK**.

Generating a Grid Report



The Grid Report is a PDF view of the content on the page. Select **View Grid Report** from the Page Action bar to generate a PDF. When the **Preview** page opens with the generated PDF, print and/or export the Grid Report if needed.

Controls Page

FIGURE 29. Controls Page

The screenshot shows the 'Controls' page in the 'Assay Management' system. The page has a header with 'Assay Management' and 'Luminex' logos. Below the header is a navigation bar with 'Assay Management' and 'Controls' tabs. A table displays control data with columns for Name, Manufacturer, Lot Number, Lot Expiration, Received Date, and Assay. The table contains three rows of control data, each with a 'Tests' section showing results for various targets (Target1-5) and test styles (TestLabelStyle, TestEditorStyle). At the bottom, there is a toolbar with 'Refresh', 'New Control', 'Edit Control', and 'Delete Control' buttons, and a 'Help' icon. A footer bar shows the user 'admin' and the instrument 'ORBIT'.

Name	Manufacturer	Lot Number	Lot Expiration	Received Date	Assay																
Control 1	LMNX				VAL1 31 1																
<table border="1"> <thead> <tr> <th>Tests</th> <th>Target1 Target1 Not Present</th> <th>Target2 Target2 Not Present</th> <th>Target3 Target3 Not Present</th> <th>Target4 Target4 Not Present</th> <th>Target5 Target5 Not Present</th> <th>TestLabelStyle</th> <th>TestEditorStyle</th> </tr> </thead> <tbody> <tr> <td>Negative</td> <td>✓</td> <td>✓</td> <td>✓</td> <td>✓</td> <td>✓</td> <td></td> <td></td> </tr> </tbody> </table>						Tests	Target1 Target1 Not Present	Target2 Target2 Not Present	Target3 Target3 Not Present	Target4 Target4 Not Present	Target5 Target5 Not Present	TestLabelStyle	TestEditorStyle	Negative	✓	✓	✓	✓	✓		
Tests	Target1 Target1 Not Present	Target2 Target2 Not Present	Target3 Target3 Not Present	Target4 Target4 Not Present	Target5 Target5 Not Present	TestLabelStyle	TestEditorStyle														
Negative	✓	✓	✓	✓	✓																
HSV1Pos	Luminex	dfgert45655t76534er	01/15/2016	01/15/2016	SW HSV Assay HS 1																
<table border="1"> <thead> <tr> <th>Tests</th> <th>HSV HSV-1 Positive</th> <th>TestLabelStyle</th> <th>TestEditorStyle</th> </tr> </thead> <tbody> <tr> <td>Positive</td> <td>✓</td> <td></td> <td></td> </tr> </tbody> </table>						Tests	HSV HSV-1 Positive	TestLabelStyle	TestEditorStyle	Positive	✓										
Tests	HSV HSV-1 Positive	TestLabelStyle	TestEditorStyle																		
Positive	✓																				
HSVNegative		ert4465465765765	01/15/2016	01/15/2016	SW HSV Assay HS 1																
<table border="1"> <thead> <tr> <th>Tests</th> <th>HSV HSV Negative</th> <th>TestLabelStyle</th> <th>TestEditorStyle</th> </tr> </thead> <tbody> <tr> <td>Negative</td> <td>✓</td> <td></td> <td></td> </tr> </tbody> </table>						Tests	HSV HSV Negative	TestLabelStyle	TestEditorStyle	Negative	✓										
Tests	HSV HSV Negative	TestLabelStyle	TestEditorStyle																		
Negative	✓																				

Creating a Control Lot

1. Select  in the upper left-hand corner of the screen and navigate to **Assay Management > Controls**.



2. Select **New Control** from the Page Action bar.
3. Enter the following required information: **Name** and **Assay**.

NOTE: The control name is unique to the selected assay. If you have more than one control using the same assay, the control names must be different.



4. Select the **Expected Results** field. The **Expected Results** dialog box opens.

- a. Choose a result for each test.



NOTE: If you do not select an expected result, the software automatically defaults the expected result to a negative.

- b. Select **Close**.
5. Select or scan **Save**.

Editing a Control Lot

1. Select  in the upper left-hand corner of the screen and navigate to **Assay Management > Controls**.
2. Select the control to edit.
3. Select  **Edit Control** from the Page Action bar.
4. Edit the control as needed.
5. Select or scan **Save**.

Deleting a Control Lot

1. Select  in the upper left-hand corner of the screen and navigate to **Assay Management > Controls**.
2. Select the control to delete.
3. Select  **Delete Control** from the Page Action bar.
4. A dialog box displays asking, “Are you sure you want to delete the control?” Select **Yes** or **No**.

Chapter 11: Security

Audit Log Page

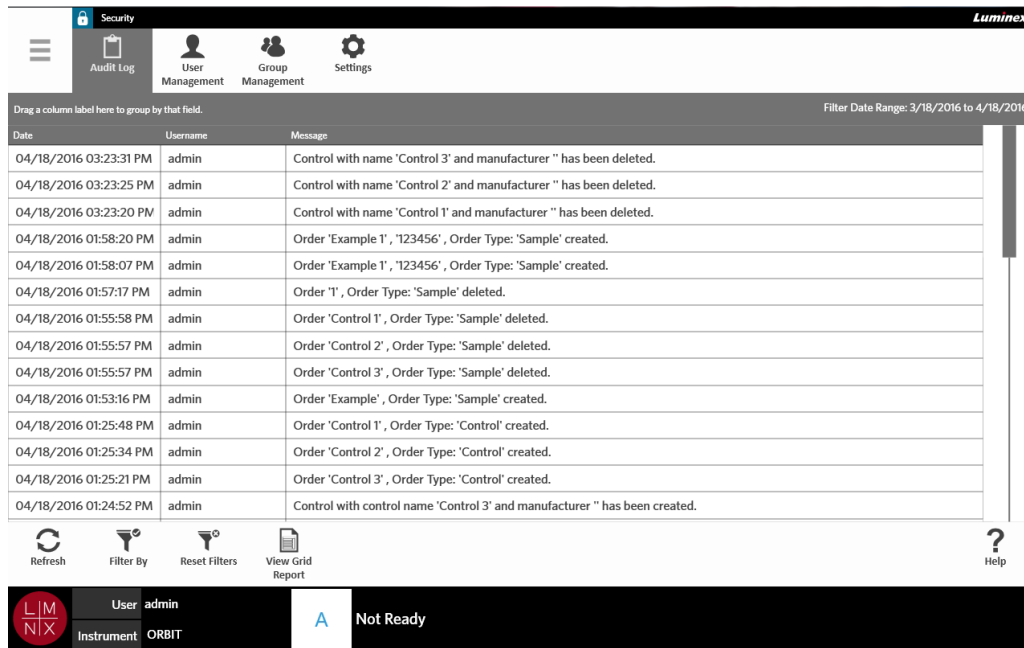

The Audit Log page allows you to keep track of who logs in and out of the ARIES® M1 System and lists any actions that were completed by a user.

FIGURE 30. Audit Log Page



Filtering the Audit Log

Filters will revert back to default settings each time you select Filter By from the Page Action bar. To keep filters from reverting back to the default settings, you must enable Persist Filters. To enable Persist Filters, see “Enabling Persist Filters” on page 85 for more information.

1. Select  in the upper left-hand corner of the screen and navigate to **Security > Audit Log**.
2. Select the  **Filter By** from the Page Action bar. The **Filter By** dialog box opens.
3. Choose the type of filter you want to use. The options are:
 - **User**
 - **Time Range**
 - **Date From and Date To**
4. Select **OK**.

Resetting Filters



To reset your filters and go back to the default settings, select **Reset Filters** from the Page Action bar.

Generating a Grid Report



The Grid Report is a PDF view of the content on the page. Select **View Grid Report** from the Page Action bar to generate a PDF. When the **Preview** page opens with the generated PDF, print and/or export the Grid Report if needed.



User Management Page

The User Management page allows you to Activate, Lock, Create, and Edit users.

FIGURE 31. User Management Page

Login	Name	User Type	Active	Locked
admin	System Administrator	Administrator	✓	
Reviewer	Luminex Reviewer	Reviewer	✓	
Supervisor	Luminex Supervisor	Supervisor	✓	
Technician1	Luminex Technician 1	Technician1	✓	
Technician2	Luminex Technician 2	Technician2	✓	

Creating Users

1. Select  in the upper left-hand corner of the screen and navigate to **Security > User Management**.
2. Select  **Create User** from the Page Action bar.



3. Enter the user information in the **Create User** dialog box.

NOTE: The user name is restricted by its length and can only contain letters and numbers. The length of the user name can be configured by the administrator.

NOTE: The password is restricted by its length and can only contain letters, numbers, and the following special characters: !, ~, @, #, \$, %, &, *, (,), _, +, ?, <, >,], and [. The length of the password can be configured by the administrator.

4. If the user is able to log in by scanning an ID badge, then select the **Barcode** field and scan the user's ID badge with the hand-held barcode reader. You do not need to enter a password if you are logging in this way. To log in with a badge, see "Logging into the ARIES[®] M1 System using your ID Badge" on page 26 for more information.
5. Select **OK**.



Editing Users

1. Select  in the upper left-hand corner of the screen and navigate to **Security > User Management**.
2. Select the user.
3. Select  from the Page Action bar. The **Edit User** dialog box opens.
4. Edit the fields in the **Edit User** dialog box as needed.
5. Select **OK**.



Changing a User's Status

The purpose of changing a user's status is to temporarily disable a user, to keep a locked user from signing into the system, and/or to unlock a user that has been automatically locked out after exceeding the maximum number of failed login attempts.

To make a user Active or Locked, complete the following:

1. Select  in the upper left-hand corner of the screen and navigate to **Security > User Management**.
2. Select the user.
3. Select  from the Page Action bar. The **Edit User** dialog box opens.
4. Toggle the **Active:** or **Locked:** button to **On** or **Off**.
5. Select **OK**.

Changing a User's Password

1. Select  in the upper left-hand corner of the screen and navigate to **Security > User Management**.
2. Select the user.
3. Select  from the Page Action bar. The **Edit User** dialog box opens.
4. Select **Change Password**.
5. Change the password. See “*Creating Users*” on page 61 for password limitations.
6. Select **OK**.

Group Management Page

The Group Management page gives the administrator the option to choose which applications users have permission to view, depending on the user type.

FIGURE 32. **Group Management Page**

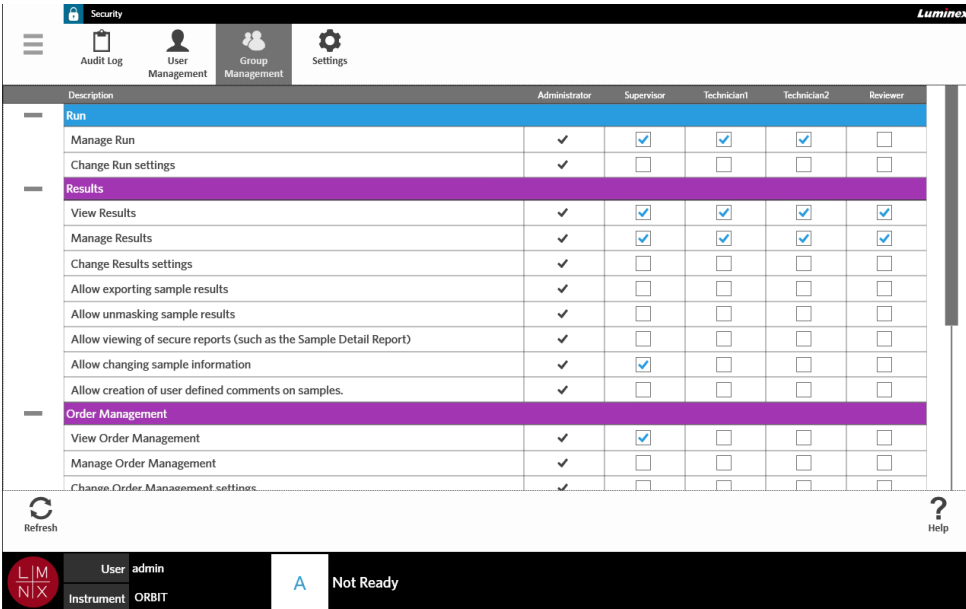

Description	Administrator	Supervisor	Technician1	Technician2	Reviewer
Run					
Manage Run	<input checked="" type="checkbox"/>	<input checked="" type="checkbox"/>	<input checked="" type="checkbox"/>	<input checked="" type="checkbox"/>	<input type="checkbox"/>
Change Run settings	<input checked="" type="checkbox"/>	<input type="checkbox"/>	<input type="checkbox"/>	<input type="checkbox"/>	<input type="checkbox"/>
Results					
View Results	<input checked="" type="checkbox"/>	<input checked="" type="checkbox"/>	<input checked="" type="checkbox"/>	<input checked="" type="checkbox"/>	<input checked="" type="checkbox"/>
Manage Results	<input checked="" type="checkbox"/>	<input checked="" type="checkbox"/>	<input checked="" type="checkbox"/>	<input checked="" type="checkbox"/>	<input checked="" type="checkbox"/>
Change Results settings	<input checked="" type="checkbox"/>	<input type="checkbox"/>	<input type="checkbox"/>	<input type="checkbox"/>	<input type="checkbox"/>
Allow exporting sample results	<input checked="" type="checkbox"/>	<input type="checkbox"/>	<input type="checkbox"/>	<input type="checkbox"/>	<input type="checkbox"/>
Allow unmasking sample results	<input checked="" type="checkbox"/>	<input type="checkbox"/>	<input type="checkbox"/>	<input type="checkbox"/>	<input type="checkbox"/>
Allow viewing of secure reports (such as the Sample Detail Report)	<input checked="" type="checkbox"/>	<input type="checkbox"/>	<input type="checkbox"/>	<input type="checkbox"/>	<input type="checkbox"/>
Allow changing sample information	<input checked="" type="checkbox"/>	<input checked="" type="checkbox"/>	<input type="checkbox"/>	<input type="checkbox"/>	<input type="checkbox"/>
Allow creation of user defined comments on samples.	<input checked="" type="checkbox"/>	<input type="checkbox"/>	<input type="checkbox"/>	<input type="checkbox"/>	<input type="checkbox"/>
Order Management					
View Order Management	<input checked="" type="checkbox"/>	<input checked="" type="checkbox"/>	<input type="checkbox"/>	<input type="checkbox"/>	<input type="checkbox"/>
Manage Order Management	<input checked="" type="checkbox"/>	<input type="checkbox"/>	<input type="checkbox"/>	<input type="checkbox"/>	<input type="checkbox"/>
Change Order Management settings	<input checked="" type="checkbox"/>	<input type="checkbox"/>	<input type="checkbox"/>	<input type="checkbox"/>	<input type="checkbox"/>

Assigning Permissions

To grant or remove permissions, complete the following:

1. Select  in the upper left-hand corner of the screen and navigate to **Security > Group Management**.
2. Select the check boxes within the different applications for each user type.

Security Settings Page

The Security Settings page allows you to adjust the User Settings, System Settings, and Password Settings.

FIGURE 33. Security Settings Page

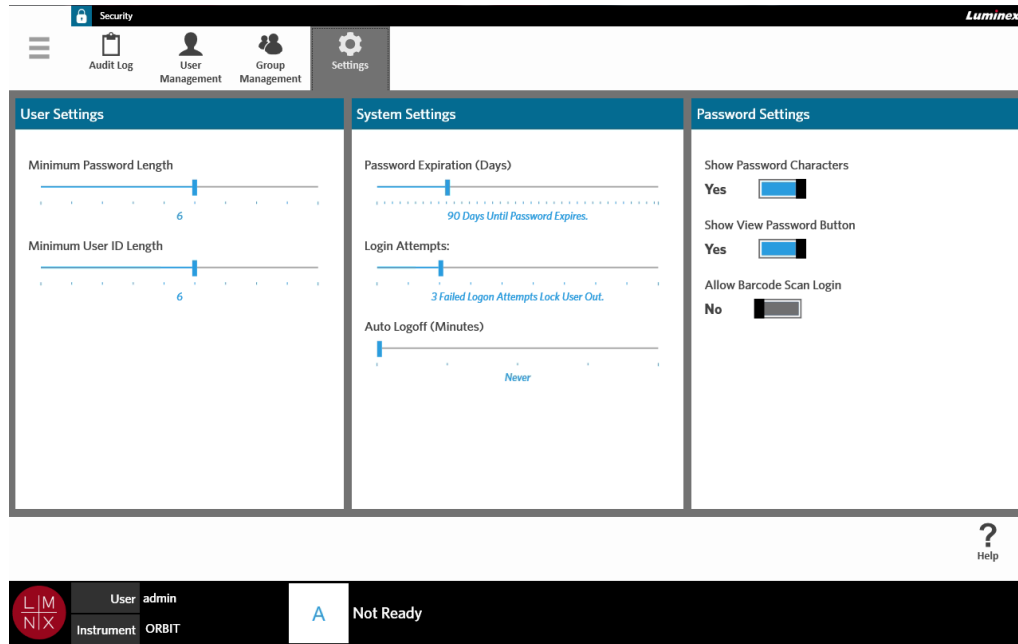

Changing the User Settings

1. Select  in the upper left-hand corner of the screen and navigate to **Security > Settings**.
2. To change the **User Settings**, select and hold each slide bar and slide to the desired minimum password length and user ID length.

Changing the System Settings

1. Select  in the upper left-hand corner of the screen and navigate to **Security > Settings**.
2. To change the **System Settings**, select and hold each slide bar and slide to the desired settings.
 - **Password Expiration (Days)** - Password expires after the specified amount of days.
 - **Login Attempts** - Locks users out of the software after so many failed login attempts.
 - **Auto Logoff (Minutes)** - System automatically logs the user out after a specified amount of time.
3. To disable the **Password Expiration (Days)**, slide the slide bar all the way to the left.

NOTE: Notice that once the slide bar is all the way to the left, the blue notification under the slide bar states, **Disabled**.

Changing the Password Settings

1. Select  in the upper left-hand corner of the screen and navigate to **Security > Settings**.
2. To change the **Password Settings**, toggle the buttons to **Yes** or **No**.
 - **Show Password Characters** - Briefly shows the password as the user types.
 - **Show View Password Button** - The eye icon next to the password field. Select to view password.
 - **Allow Barcode Scan Login** - Allows users to login by barcode scan.

Chapter 12: Administration

Lab/Site Information Page

The Lab/Site Information page allows you to customize the Lab Settings and Report Headers for your system.

FIGURE 34. Lab/Site Information Page

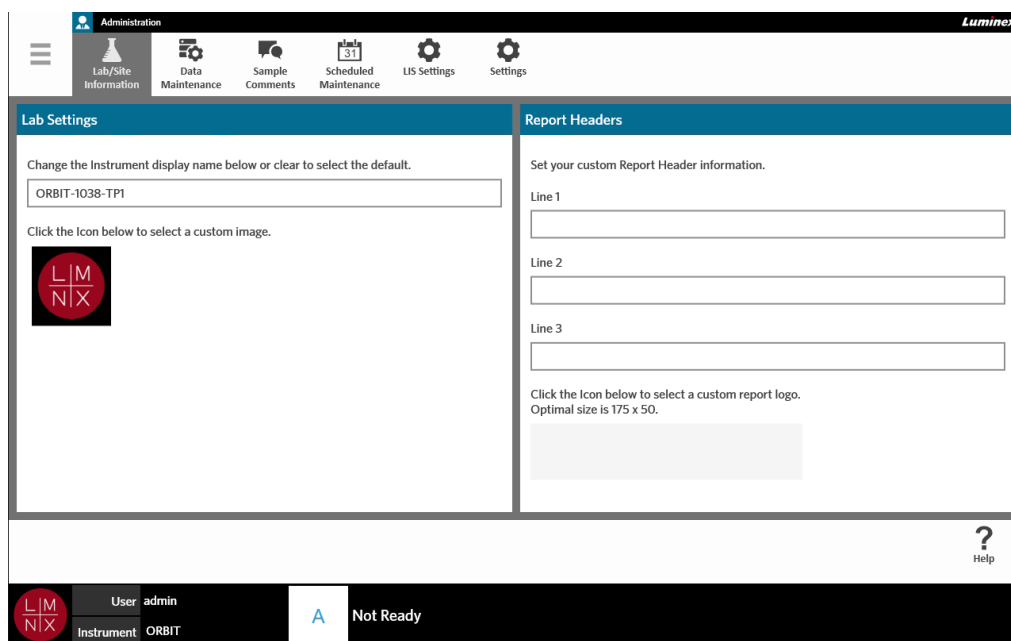

Changing the Instrument Display Name

The instrument display name is customizable for each instrument. The name is also used for the default run names and for file names. By default, the system assigns an instrument name automatically. Administration rights may be required to change these settings.

FIGURE 35. Instrument Display Name



NOTE: The instrument name and computer name are not the same.

1. Select  in the upper left-hand corner of the screen and navigate to **Administration > Lab/Site Information**.
2. Enter the desired name into the text field of the **Lab Settings** dialog box.
3. To return to the default instrument name, delete the name you entered above.

Changing the Instrument Icon

The instrument icon is customizable for each instrument. The image is located at the bottom left-hand corner of the screen.

FIGURE 36. Instrument Icon



1. Select  in the upper left-hand corner of the screen and navigate to **Administration > Lab/Site Information**.
2. Select the icon below the following sentence on the screen: **Click the icon below to select a custom image**. The **Import File** dialog box opens.
 - a. Choose the **Location** and **File Name** that contains the image. The ARIES[®] M1 System only supports PNG and GIF files.
 - b. Select **OK**.

Customizing the Report Headers for Reports

The Report Headers are headers on a report that can contain customized information (e.g., laboratory name, department name, or hospital name). The following figure is an example of where the report headers are located on a report.

FIGURE 37. Report Headers

Position	Accession ID	Sample ID	Assay Name	Test Result
A1		Sample 5	Luminex_HSV_IUO	HSV 1 Positive

Channel	Channel Desc.	Ct	Tm (C)	Channel Result
1	Not Used	-	-	-
2	HSV	32.6	85.6	Detected

To customize the report headers, complete the following:

1. Select  in the upper left-hand corner of the screen and navigate to **Administration > Lab/Site Information**.
2. In the **Report Headers** dialog box, fill in **Line 1**, **Line 2**, and **Line 3** with the desired report headers.

- If the keyboard is in the way, select the blue “x” at the bottom right-hand corner of the keyboard to close.

Customizing the Report Logo

The report logo is the image located at the top of a report. The following figure is an example of where the report logo is located on a report.

FIGURE 38. Report Logo

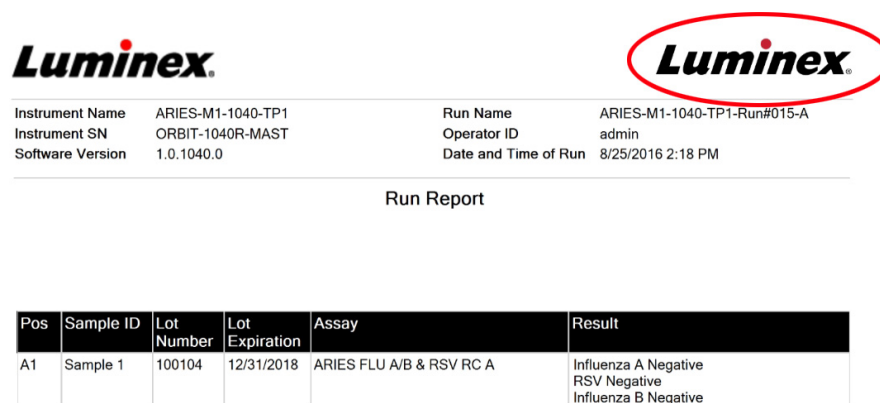

The screenshot shows a report header with the Luminex logo on the left and right. The right logo is circled in red. Below the logos is a table of instrument and run information:

Instrument Name	ARIES-M1-1040-TP1	Run Name	ARIES-M1-1040-TP1-Run#015-A
Instrument SN	ORBIT-1040R-MAST	Operator ID	admin
Software Version	1.0.1040.0	Date and Time of Run	8/25/2016 2:18 PM

Below this is the title "Run Report" and a table of results:

Pos	Sample ID	Lot Number	Lot Expiration	Assay	Result
A1	Sample 1	100104	12/31/2018	ARIES FLU A/B & RSV RC A	Influenza A Negative RSV Negative Influenza B Negative

To customize the report logo, complete the following:

- Select  in the upper left-hand corner of the screen and navigate to **Administration > Lab/Site Information**.
- Below the sentences **Click the icon below to select a custom report logo. Optimal size is 175 x 50.**, select the light gray rectangle. The **Import File** dialog box opens.
 - Choose the **Location** and **File Name** that contain the image. The ARIES[®] M1 System only supports PNG and GIF files.
 - Select **OK**.

Data Maintenance Page

To view the Data Maintenance page, select  in the upper left-hand corner of the screen and navigate to **Administration > Data Maintenance**.

In the Database dialog box you can view how much database space is being used and how many total runs have been completed.

In the Archive dialog box you can specify which runs and logs are to be archived and designate a folder for archive and backup.

FIGURE 39. Data Maintenance Page

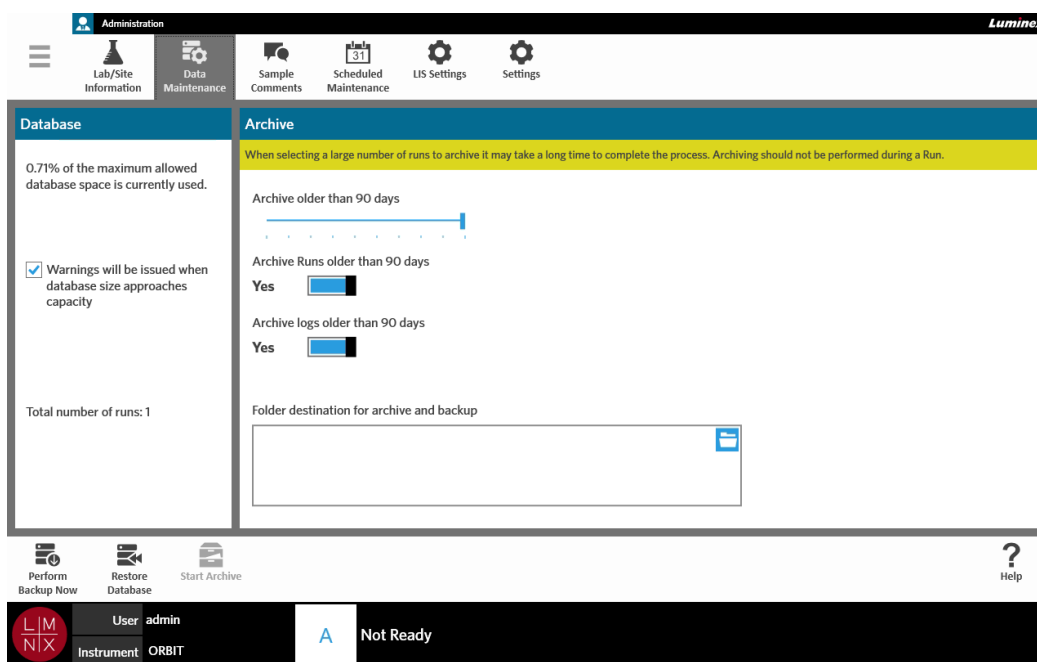

Setting up the Archive



CAUTION: When selecting a large number of runs to archive, it may take a long time to complete the process. Archiving should not be performed during a run.

1. Select  in the upper left-hand corner of the screen and navigate to **Administration > Data Maintenance**.
2. If you want to archive runs older than a certain amount of days, toggle the **Archive Runs older than X days** button to **Yes**.
3. If you want to archive logs older than a certain amount of days, toggle the **Archive logs older than X days** button to **Yes**.
4. Select and hold the **Archive older than X days** slide bar and slide to the desired number of days. Notice that the number of days changes in the toggle buttons as well when you move the slide bar.
5. Set the folder destination for the archive and backup by selecting the folder icon in the upper right-hand corner of the **Folder destination for archive and backup** box. The **Select Folder** dialog box opens.
 - a. Choose the **Location** for the archive and backup.
 - b. Select **OK**.

Performing a Backup

Performing a backup generates a backup file that contains the complete ARIES® database. Perform a backup as recommended by your IT department and/or before attempting any software or system upgrades.

WARNING: Restoring the database from a backup file may affect ARIES® calibration settings. If the instrument has been serviced or the module has been replaced since the backup was taken, this may revert the module to its original calibration settings or render the module inoperable. Only restore from a backup if no instrument calibration settings have been changed since the date of the backup.



1. Select  in the upper left-hand corner of the screen and navigate to **Administration > Data Maintenance**.
2. Select  from the Page Action bar. The **Export File** dialog box displays.
 - a. Choose the **Location** for the backup.
 - b. Select **OK**.
3. The **Messages** dialog box displays informing you that the backup completed successfully. Select **OK**.

Restoring the Database

If needed, you can restore your system to an earlier state by restoring the database from a previously backed up copy.

CAUTION: Do **not** turn off the instrument or disconnect the power during a restore operation.



WARNING: Restoring the database from a backup file may affect ARIES® calibration settings. If the instrument has been serviced or the module has been replaced since the backup was taken, this may revert the module to its original calibration settings or render the module inoperable. Only restore from a backup if no instrument calibration settings have been changed since the date of the backup.

1. Select  in the upper left-hand corner of the screen and navigate to **Administration > Data Maintenance**.
2. Select  from the Page Action bar. The **Import File** dialog box opens.
 - a. Choose the **Location** and **File Name** of the Database files.
 - b. Select **OK**.
3. A dialog box opens asking, *“To perform a restore of the system database, the system must restart. The process could take a few minutes, depending on the size of your database backup. Press “OK” to restart the system and restore the database.”* Select **OK**.

Starting the Archive

The purpose of archiving is to remove run data from the active database (Results page) to an archive location. Follow your laboratory's data retention policy when deciding how often to archive. The run data is no longer accessible on the ARIES® M1 System after the archive. Archived data cannot be re-imported back onto the ARIES® M1 System, but can be viewed on another PC. Data is exported as CSV files.

NOTE: A folder destination for the archive must be set before starting the archive.

1. Select  in the upper left-hand corner of the screen and navigate to **Administration > Data Maintenance**.
2. Set the folder destination, see “*Setting up the Archive*” on page 69 for more information. If this folder has already been designated, continue to the next step.
3. Select  from the Page Action bar. The **Archive Data** dialog box opens.

NOTE: Be aware that logs older than the specified amount of days in the **Archive** dialog box will also be archived if the **Archive logs older than X days** toggle button is set to **Yes**.

4. Select the run(s) you want to archive. All runs in the database are listed for selection. Runs that are older than the specified number of days are automatically selected for archival, but can be manually deselected if desired.
5. Select **Archive**. A status bar will display saying, “*Archive started. Data will be exported in (folder destination).*”
6. The **Messages** dialog box displays, informing you that the archive was successful. Select **OK**.



Sample Comments Page

The Sample Comments page allows you to create, edit, and delete comments. You can also add comments to the cassette information from the Run page or the Results page. To add comments to the cassette information from the Run page or the Results page, see “*Adding a Sample Comment to a Cassette from the Run Page*” on page 35 or “*Adding a Sample Comment to a Result from the Results Page*” on page 42 for more information.

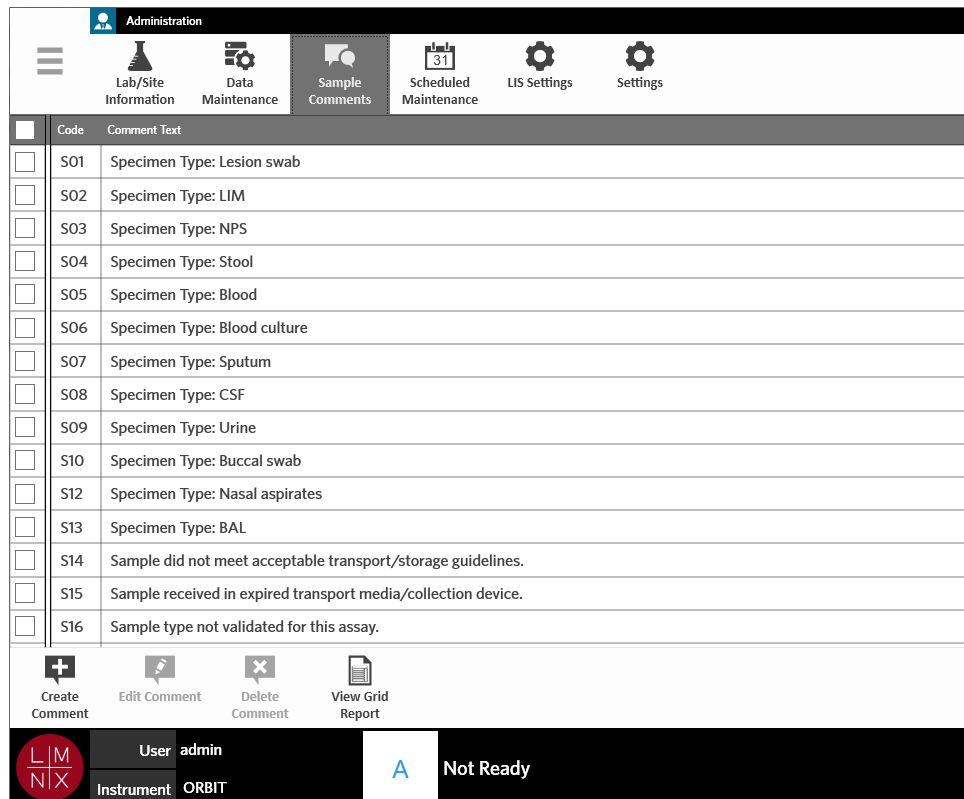

FIGURE 40. Sample Comments Page





Creating Sample Comments

1. Select  in the upper left-hand corner of the screen and navigate to **Administration > Sample Comments**.
2. Select the  from the Page Action bar. The **Create New Comment** dialog box opens.
3. Fill in the required fields.
4. Select **Save**.

Editing Sample Comments

1. Select  in the upper left-hand corner of the screen and navigate to **Administration > Sample Comments**.
2. Select the comment.
3. Select  from the Page Action bar. The **Edit Existing Comment** dialog box opens.
4. Make changes to the comment in the **Comment Text** box.
5. Select **Save**.

Deleting Sample Comments

1. Select  in the upper left-hand corner of the screen and navigate to **Administration > Sample Comments**.
2. Select the comment.
3. Select  from the Page Action bar.

NOTE: When you select **Delete Comment**, the comment deletes without warning.

Generating a Grid Report

The Grid Report is a PDF view of the content on the page. Select  from the Page Action bar to generate a PDF. When the **Preview** page opens with the generated PDF, print and/or export the Grid Report if needed.

Scheduled Maintenance Page

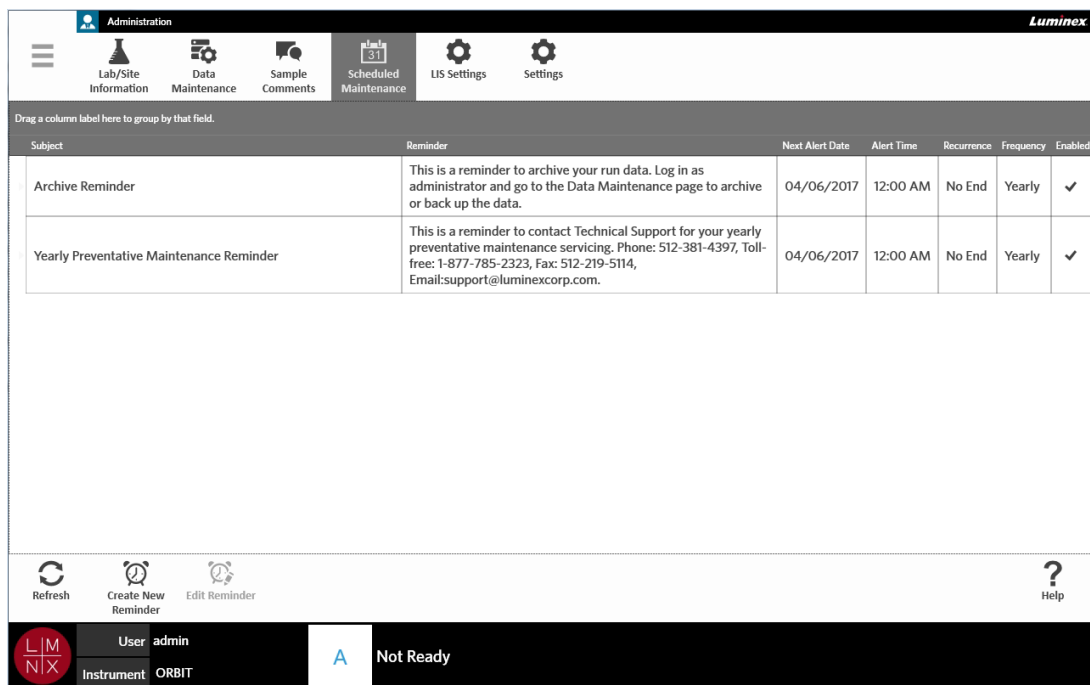

The Scheduled Maintenance page allows you to create, edit, and delete reminders for maintenance throughout the year. For example, you can create a reminder to run controls at specified times.

FIGURE 41. Scheduled Maintenance Page





Subject	Reminder	Next Alert Date	Alert Time	Recurrence	Frequency	Enabled
Archive Reminder	This is a reminder to archive your run data. Log in as administrator and go to the Data Maintenance page to archive or back up the data.	04/06/2017	12:00 AM	No End	Yearly	✓
Yearly Preventative Maintenance Reminder	This is a reminder to contact Technical Support for your yearly preventative maintenance servicing. Phone: 512-381-4397, Toll-free: 1-877-785-2323, Fax: 512-219-5114, Email:support@luminexcorp.com.	04/06/2017	12:00 AM	No End	Yearly	✓



Creating a New Reminder

1. Select  in the upper left-hand corner of the screen and navigate to **Administration > Scheduled Maintenance**.
2. Select  from the Page Action bar. The **Create Reminder** dialog box opens.
3. Fill in the required information.
4. Toggle the **Enabled** button to **On**.
5. Select **Save**.

Editing a Reminder

1. Select  in the upper left-hand corner of the screen and navigate to **Administration > Scheduled Maintenance**.
2. Select the reminder to edit.
3. Select  from the Page Action bar. The **Edit Reminder** dialog box opens.
4. Edit the information as needed.
5. Select **Save**.

Deleting a Reminder

1. Select  in the upper left-hand corner of the screen and navigate to **Administration > Scheduled Maintenance**.
2. Select the reminder to delete.
3. Select  from the Page Action bar. The **Edit Reminder** dialog box opens.
4. Select **Delete**.

NOTE: The software does not ask you to confirm before deleting the reminder. Ensure that you have the correct reminder selected before deleting.

LIS Settings Page

NOTE: Validation of the LIS compatibility must be performed by the user.

FIGURE 42. LIS Settings Page

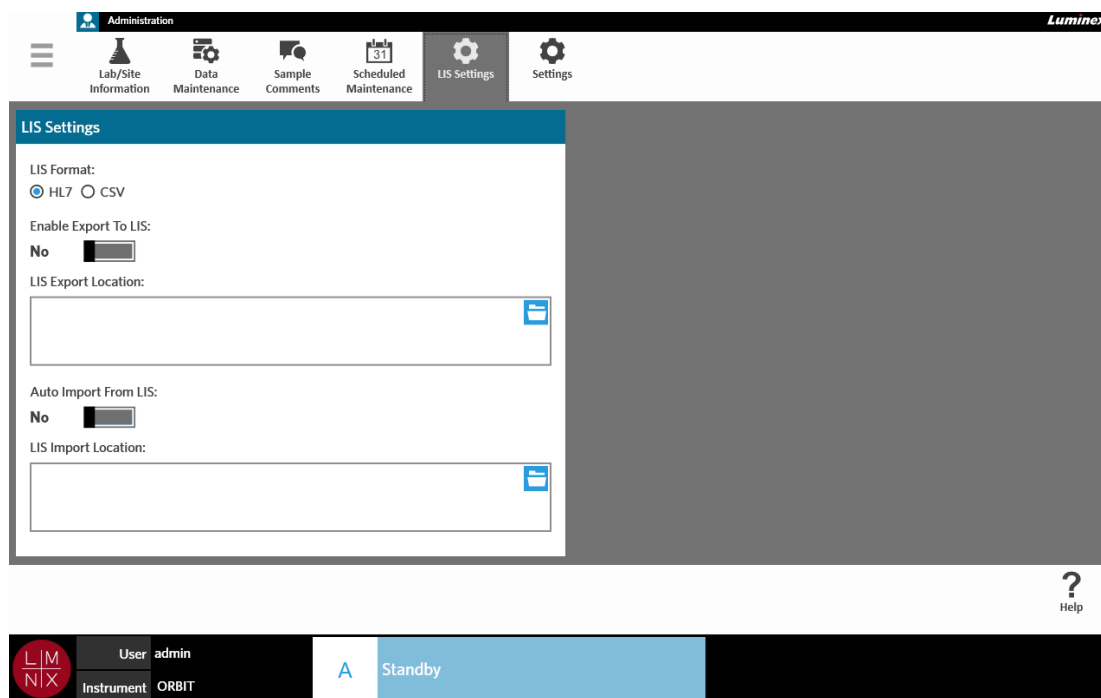

Selecting an LIS Format

The ARIES® M1 System supports two types of LIS file formats: Comma Separated Values (CSV) and Health Level Seven (HL7).

HL7

The HL7 format is specified by the Health Level Seven International standards organization. The HL7 format allows types of medical data to be captured in segments, with each segment designed to express different medical properties.

CSV

The CSV is useful when you want to import data into spreadsheets.

1. Select  in the upper left-hand corner of the screen and navigate to **Administration > LIS Settings**.
2. Select the **HL7** radio button or the **CSV** radio button.

Automatically Exporting to LIS

Auto Export To LIS exports sample results to the LIS after a run completes.

1. Select  in the upper left-hand corner of the screen and navigate to **Administration > LIS Settings**.
2. Toggle the **Enable Export To LIS** button to **Yes**.
3. Toggle the **Auto Export To LIS** button to **Yes**.
4. Enter the **LIS Export Location** by selecting the folder icon in the upper right-hand corner of the **LIS Export Location** box. The **Select Folder** dialog box opens.
 - a. Choose the **Location** for the export.
 - b. Select **OK**.

Automatically Importing from LIS

Auto Import From LIS imports orders to the instrument from the LIS.

1. Select  in the upper left-hand corner of the screen and navigate to **Administration > LIS Settings**.
2. Toggle the **Auto Import From LIS** button to **Yes**.
3. Enter the **LIS Import Location** by selecting the folder icon in the upper right-hand corner of the **LIS Import Location** box. The **Select Folder** dialog box opens.
 - a. Choose the **Location** for the import.
 - b. Select **OK**.

Administration Settings Page



The Administration Settings page allows you to adjust the system settings and local settings on the instrument.

WARNING: Some of these settings require the system to reboot into administration mode. Do not reboot the system while a run is in progress.

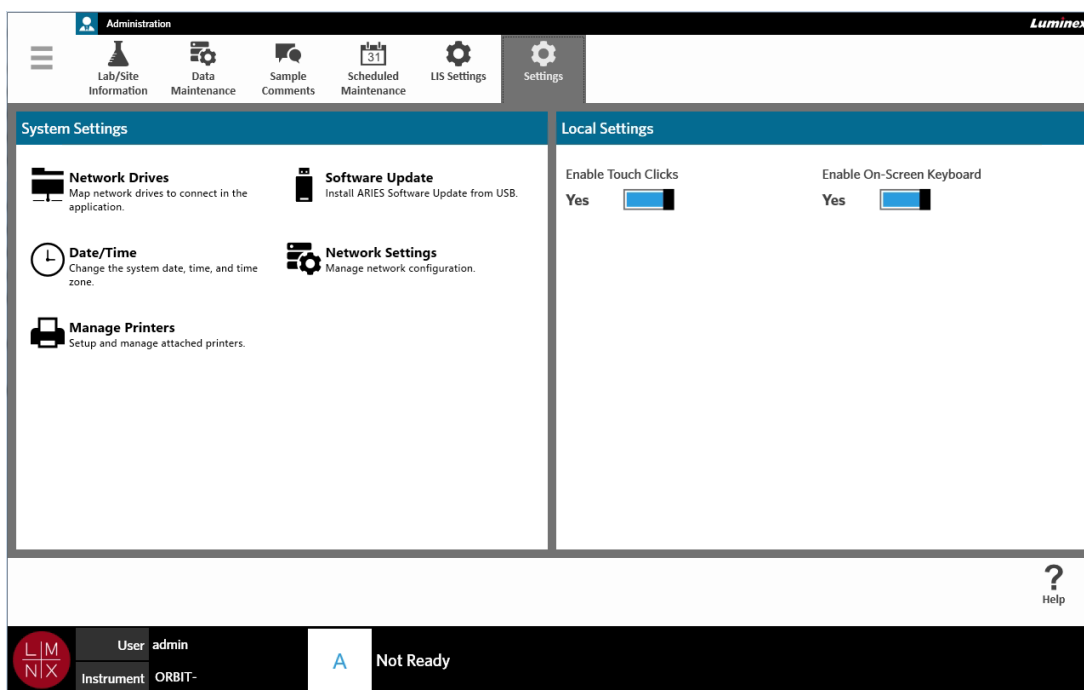
FIGURE 43. Administration Settings Page



Managing Printers

1. Select  in the upper left-hand corner of the screen and navigate to **Administration > Settings**.
2. Select **Manage Printers**. A message displays asking, “*Changes to these settings require a reboot of the machine. Do you want to reboot now?*” Select **Yes**. The system will now reboot.
3. Once rebooted, select **Manage Printers** again. The **Printers** dialog box opens.
4. From here you can add a printer, set a printer as default, or delete printers. To set up a network printer, see “*Installing a Network Printer*” for instructions.
5. Once changes are complete, the system must be rebooted again. Select  from the Page Action bar. A message displays stating, “*The instrument will now commit all changes to the hard drive. Manually powering off the instrument during this time can corrupt the disk and prevent the system from starting.*” Select **OK**.

Installing Network Drives



You may need to contact your IT department for some of the information needed below.

1. Select  in the upper left-hand corner of the screen and navigate to **Administration > Settings**.
2. Select **Network Drives**.
3. Select the letter of the drive from the **Drive:** drop-down menu.
4. Enter a folder location into the **Folder:** text box (e.g., \\server\share).
5. Select the **Connect using different credentials** check box.
6. Enter the **Username**, **Password**, and **Domain**.



7. Select **Map Drive**.

Setting Network Settings



You may need to contact your IT department for some of the information needed below.

1. Select  in the upper left-hand corner of the screen and navigate to **Administration > Settings**.
2. Select **Network Settings**. A message displays asking, “Changes to these settings require a reboot of the machine. Do you want to reboot now?” Select **Yes**. The system will now reboot.
3. Once rebooted, select **Network Settings** again. The **Network Settings** dialog box opens.
4. Make changes to the network settings as needed.
5. Select **Apply**.
6. Once changes are complete, the system must be rebooted again. Select  from the Page Action bar. A message displays stating, “The instrument will now commit all changes to the hard drive. Manually powering off the instrument during this time can corrupt the disk and prevent the system from starting.” Select **OK**.

Setting the Date and Time

1. Select  in the upper left-hand corner of the screen and navigate to **Administration > Settings**.
2. Select **Date/Time**. A message displays asking, “Changes to these settings require a reboot of the machine. Do you want to reboot now?” Select **Yes**. The system will now reboot.
3. Once rebooted, select **Date/Time** again. The **Date and Time** dialog box opens (this is a Windows® dialog box).
4. From the **Date and Time** tab, change the date and time and/or change the time zone by following the on-screen prompts.
5. Select **OK**.
6. Once changes are complete, the system must be rebooted again. Select  from the Page Action bar. A message displays stating, “The instrument will now commit all changes to the hard drive. Manually powering off the instrument during this time can corrupt the disk and prevent the system from starting.” Select **OK**.

Installing Software Updates

1. Insert the USB flash drive that contains the software update into one of the five USB communication ports.
2. Select  in the upper left-hand corner of the screen and navigate to **System > Instrument Status** and check the **Software Version** to ensure that the update has not already been installed.
3. Select  in the upper left-hand corner of the screen and navigate to **Administration > Settings**.
4. Select **Software Update**. The **Import File** dialog box opens.
5. Choose the **Location** and **File Name** to import the software update.

6. Select **OK**.
7. A message displays stating, "*The machine must be restarted to apply this patch. Do you want to continue?*" Select **Yes**.
8. Once changes are complete, the system must be rebooted again. Select  from the Page Action bar. A message displays stating, "*The instrument will now commit changes to the hard drive. Manually powering off the instrument during this time can corrupt the disk and prevent the system from starting.*" Select **OK**.
9. Navigate back to **System > Instrument Status** and check the **Software Version** to ensure that the update installed.

Chapter 13: System

System Log Page

The System Log page contains information about the system such as when the system is turned on, when the system is shut down, and any error messages that have occurred during a run.

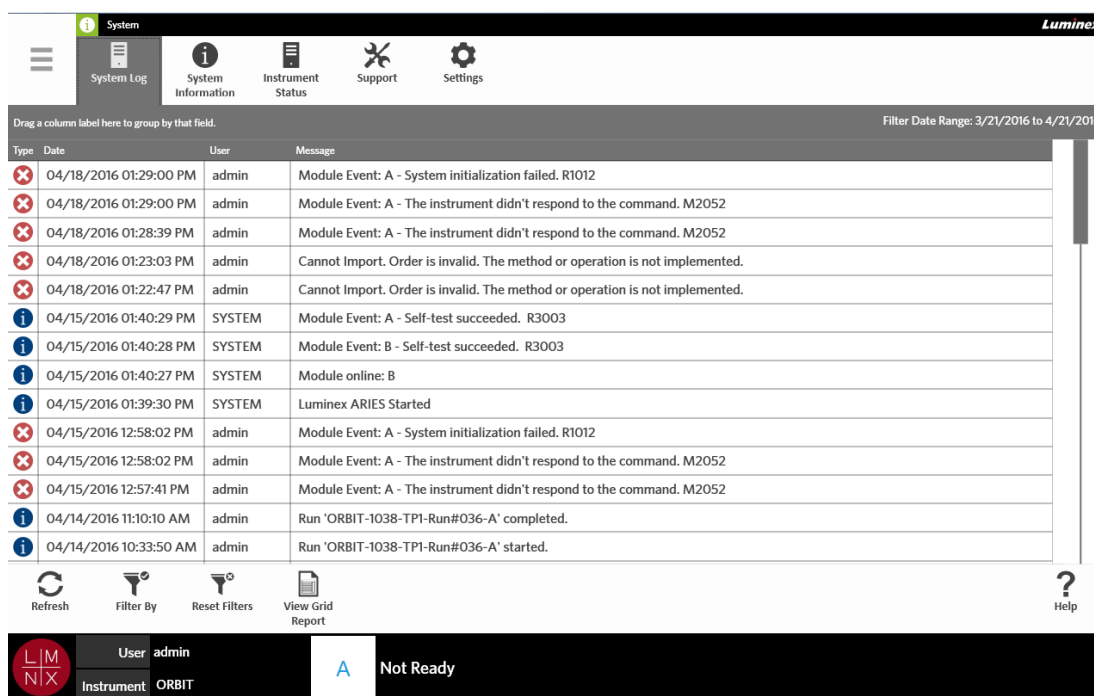

FIGURE 44. System Log Page



Generating a Grid Report

The Grid Report is a PDF view of the content on the page. Select  from the Page Action bar to generate a PDF. When the **Preview** page opens with the generated PDF, print and/or export the Grid Report if needed.

Filtering the System Log

1. Select  in the upper left-hand corner of the screen and navigate to **System > System Log**.
2. Select the  **Filter By** from the Page Action bar. The **Filter By** dialog box opens.
3. Choose the type of filter you would like to use. The options are:
 - **User**
 - **Log Level**
 - **Time Range**

- **Date From and Date To**

4. Select **OK**.

Resetting Filters



To reset your filters and return to the default view, select **Reset Filters** from the Page Action bar.

System Information Page

System Information displays the Luminex copyright information, the End-User License Agreement (EULA), the ARIES® software version, and any software updates that have been installed on the system.



To see the End-User License Agreement, select **EULA** from the Page Action bar.

FIGURE 45. **System Information Page**

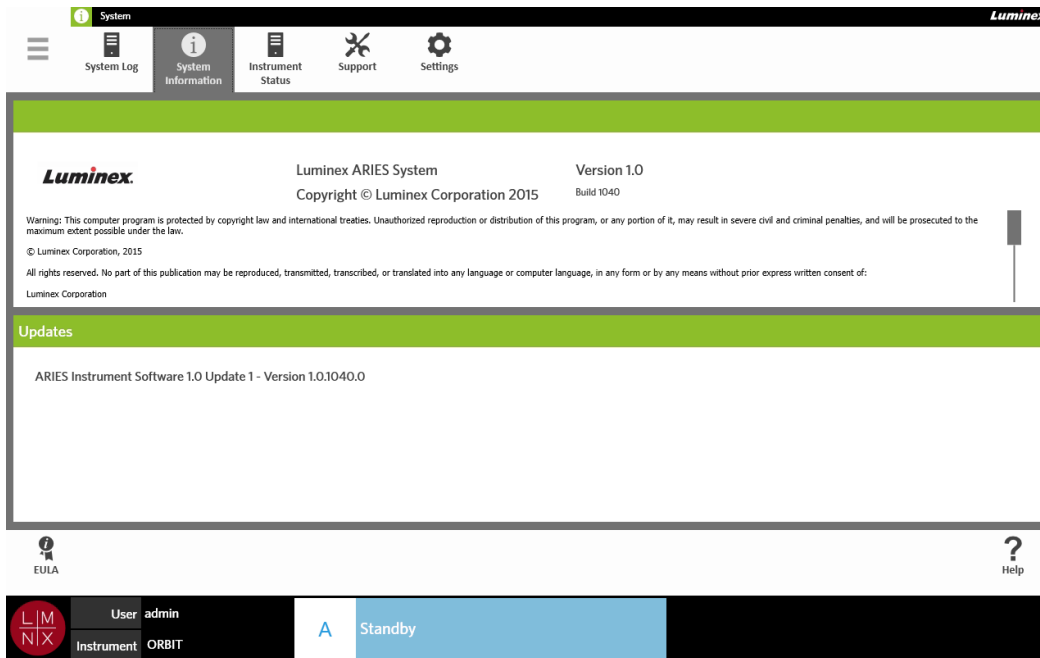

Instrument Status Page

The Instrument Status page contains the current status of the Instrument, and Module A. In addition to all of the information listed in the instrument section, all of the reminders created by the user are listed here.

FIGURE 46. Instrument Status Page

Property	Value
Instrument	
Software Name	Luminex ARIES
Software Version	1.0.1040
Software Updates	ARIES Instrument Software 1.0 Update 1 - Version 1.0.1040.0
Operating System Information	Microsoft Windows Embedded Standard 64-bit
Instrument Name	ORBIT-1040-TP1
Serial Number	ORBIT-1040R-MAST
LIS Input Folder	
LIS Output Folder	
Total System Time	2 days
Time Powered On	5/4/2016 11:12:14 AM
Archive Reminder Due	5/4/2017
Yearly Preventative Maintenance Reminder Due	5/4/2017
Module A	
Serial Number	MD16064002

The instrument section includes information on the following:

- Software Name
- Software Version
- Software Updates
- Operating System Information
- Instrument Name
- Serial Number
- LIS Input Folder
- LIS Output Folder
- Total System Time
- Time Powered On
- Archive Reminder Due
- Yearly Preventative Maintenance Reminder Due

The Module A section includes information on the following:

- Serial Number
- Firmware Version
- Status
- Total Runs

Generating a Grid Report



The Grid Report is a PDF view of the content on the page. Select **View Grid Report** from the Page Action bar to generate a PDF. When the **Preview** page opens with the generated PDF, print and/or export the Grid Report if needed.

Support Page

The Support page is where you can create a support package to submit to technical support. The support package is a large file containing all necessary logs and runs (optional) that will help Luminex Technical Support diagnose problems that have occurred on the ARIES[®] M1 System. The support package may be small enough to email if there is no run data included in the file. If the support package is larger than what your email allows, send the file through Luminex's Big File Transfer (BFT). To send the support package through BFT, enter <http://bft.luminexcorp.com/> into your web browser and follow the instructions.

WARNING: If you attach runs to the support package, they may include patient information that is protected under CLIA and HIPAA. Please follow your laboratory protocols before sending information to Luminex.

FIGURE 47. Support Page

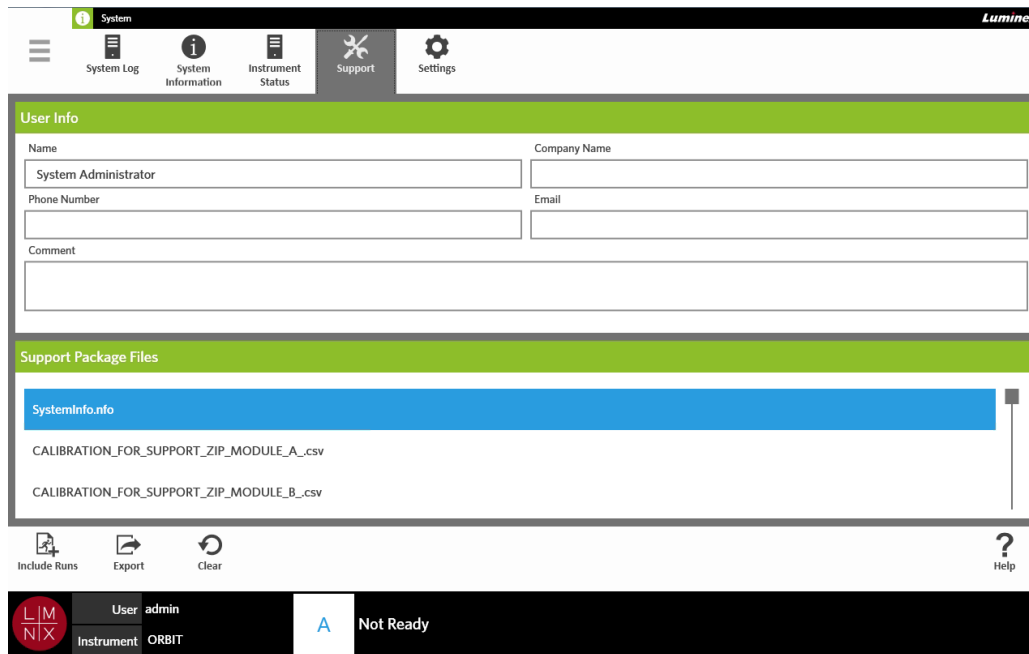

Exporting a Support Package

1. Select  in the upper left-hand corner of the screen and navigate to **System > Support**.

2. Enter information into the **User Info** dialog box (optional). If needed, you can include up to 10 runs

with the support package. Select  from the Page Action bar.

- a. Choose the run(s) from the **Include Run Information in the Support Package** dialog box.
- b. Select **OK**.

3. If you made an error and need to start over, select  from the Page Action bar. If not, then continue to the next step.

4. Select  from the Page Action bar. The **Export File** dialog box opens.

- a. Choose the **Location** for the export.
- b. Select **OK**.

5. A **Messages** dialog box opens informing you if the export was successful. Select **OK**.

6. Email the support package file to support@luminexcorp.com or send it via BFT at <http://bft.luminexcorp.com/> to Luminex Technical Support.

System Settings Page

FIGURE 48. System Settings Page

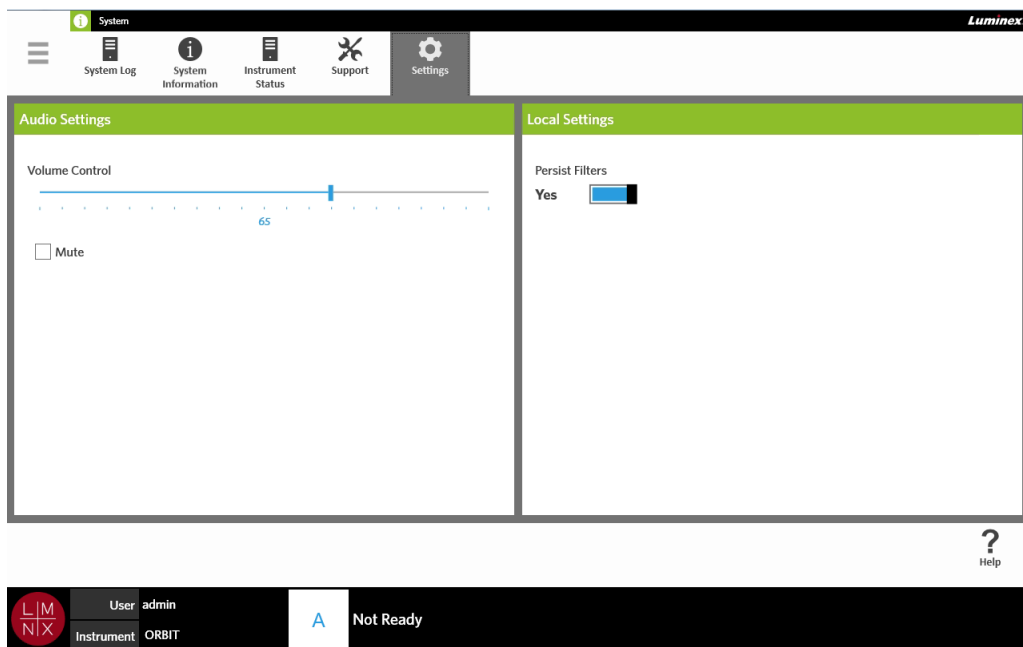

Changing the Audio Settings

To change the volume of the speakers, complete the following:

1. Select  in the upper left-hand corner of the screen and navigate to **System > Settings**.
2. In the **Audio Settings** dialog box, select and hold the **Volume Control** slide bar and slide to the desired volume level.

3. If you want to mute the sound, select the **Mute** check box.

Enabling Persist Filters

If Persist Filters is disabled, then the filtering selections made in any of the Filter By dialog boxes reverts back to the system default each time you select Filter By from the Page Action bar.







To enable Persist Filters, complete the following:

1. Select  in the upper left-hand corner of the screen and navigate to **System > Settings**.
2. Toggle the **Persist Filters** button to **Yes**.

Chapter 14: Maintenance

General Maintenance Precautions

Observe the following general maintenance precautions:

	CAUTION: Personnel who use, maintain, or clean the ARIES® M1 System should be trained in standard laboratory safety practices and should follow those practices when handling the instrument.
	CAUTION: Sample and waste fluid can contain biohazardous material, where exposure to biohazardous material, including aerosols, exists. Follow appropriate biosafety procedures, use personal protective equipment, and use ventilation devices.
	CAUTION: Do not remove the cover of the ARIES® M1 System under any circumstances. Do not place your hand or any other object inside the module opening at any time.
	CAUTION: Avoid contact with moving parts. Disconnect the instrument from the power source when the procedure instructs you to do so.
	CAUTION: Adhere to standard laboratory safety practices when handling hazardous, toxic, or flammable reagents and chemicals. Consult the package insert for the assay you are running and the Safety Data Sheet (SDS) for more information. Contact Luminex Technical Support when in doubt about compatibility of cleaning and decontamination agents or materials.
	CAUTION: Refer to the applicable SDS regarding safe handling practices for any spills.
	WARNING: Wear appropriate personal protective equipment (PPE) when handling parts that come into contact with potentially biohazardous samples.

12 Month Preventative Maintenance

Please contact Luminex Technical Support to schedule your 12 month preventative maintenance.

Routine Maintenance

Sample Prep Tray Decontamination

Luminex recommends cleaning the Sample Prep Tray (SPT) after each use to help avoid cross-contamination.

1. Wipe down the SPT surface with water and properly dispose of the cloth.
2. Wipe the SPT with 10% household bleach solution.

3. Rinse the SPT with water and allow to dry.

Daily Decontamination

Luminex recommends that the following items be cleaned daily to help avoid cross-contamination.

- Hand-held barcode reader
 - Magazine
 - Touch screen
1. Wipe down surfaces with water and properly dispose of the cloth.
 2. Wipe down surfaces with 10% household bleach and properly dispose of the cloth. Allow bleach to sit on surface for 10 minutes.
 3. Wipe down surfaces with water and allow to dry.

As Needed Maintenance

Shutting Down the ARIES® M1 System



CAUTION: Luminex does not recommend shutting down the ARIES® M1 System while a run is in progress. Doing so may cause a loss of data. The cassettes cannot be reused.

To perform a system shutdown:

1. Remove all cassettes from the magazine.
2. Place the empty magazine back into the module.
3. Push the power button located on the front of the instrument. Do not press and hold the power button.

ARIES® M1 System Decontamination

Occasions can arise when it becomes necessary to decontaminate the entire ARIES® M1 System, for example, prior to shipping. This is particularly important when biohazardous samples have been run. For questions on cleaning reagents, contact Luminex Technical Support.

NOTE: The ARIES® M1 System must be powered down before disinfecting. Do not directly spray any parts of the system with cleaning solutions.

1. Power down the ARIES® M1 system.
2. Wipe down instrument surface with water and properly dispose of the cloth.
3. Wipe down instrument surface with 10% household bleach and properly dispose of the cloth. Allow bleach to sit on surface for 10 minutes.
4. Wipe down surfaces with water and allow to dry.

Replacing the Power Cord

For a replacement power cord, contact Luminex Technical Support.

CAUTION: Be aware, before attempting any necessary lifting or movement of the instrument, that it weighs approximately 35.6 kg (78.5 lbs). Lifting the instrument requires two people.



1. Turn off the ARIES® M1 System and unplug the power cord from the wall or UPS.
2. Unplug the power cord from the back of the ARIES® M1 System.
3. Take the new power cord and plug the cord into the back of the ARIES® M1 System.
4. Plug the power cord into the wall or UPS.

Replacing Fuses

Periodically, you might need to replace a fuse on the ARIES® M1 System. The instrument requires fuses with the following specifications:

F5A, 250 V

The fuse cartridge will accept either 5 mm x 20 mm or 0.25" x 1.25" fuses. Fuses are available from Luminex Corporation. Replacing a fuse requires access to the back of the ARIES® M1 System.

	DANGER: To avoid serious injury or death by electric shock, you must turn off the ARIES® M1 System and unplug it from the wall before replacing a fuse.
	WARNING: Replace with Luminex recommended fuses only.
CAUTION: Be aware, before attempting any necessary lifting or movement of the instrument, that it weighs approximately 35.6 kg (78.5 lbs). Lifting the instrument requires two people.	

To replace a fuse:

1. Turn off the ARIES® M1 System and unplug the power cable from the back.

2. Use a small, flat-head screwdriver to open the fuse cover on the lower left corner of the back of the instrument. The fuse cover opens downward. Inside are two cartridges: a red one on top and a black one on the bottom.



3. Use the screwdriver to remove the red cartridge.



4. Check both of the fuses in the cartridge for damage. A fuse can display physical evidence of damage, for example, broken wire or blackened glass. If the fuse displays no damage, test it for continuity with a voltmeter.

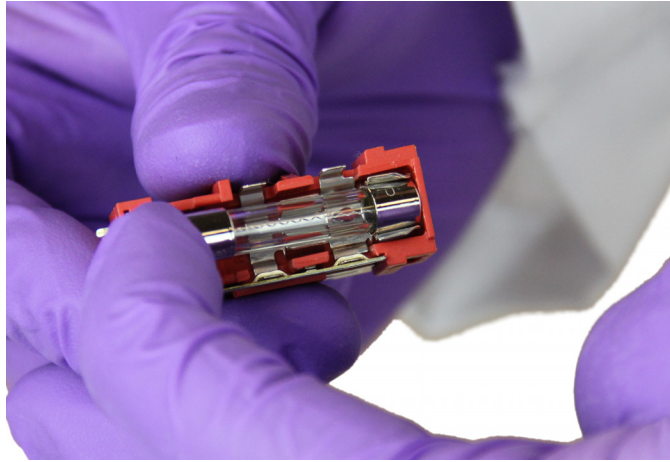

5. Replace the damaged fuse(s) with the type specified on the sticker to the right of the power input module.

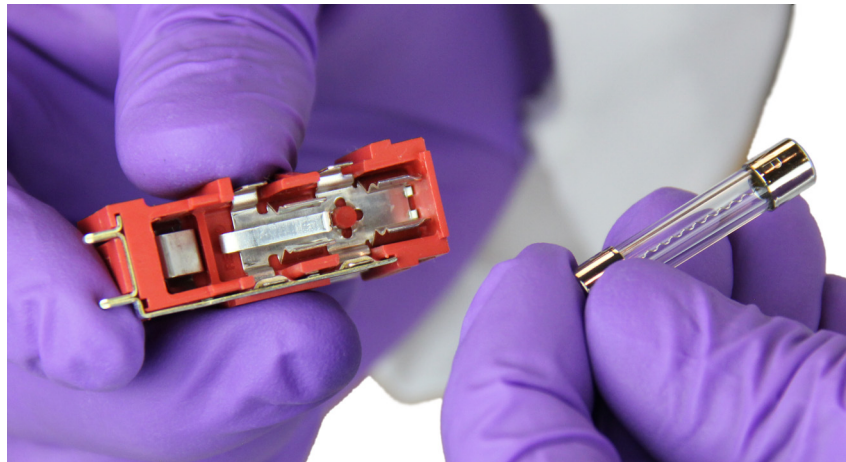

6. Replace the red cartridge.



7. Close the fuse cover.



8. Plug in the power cord and turn on the ARIES® M1 System.

Chapter 15: Troubleshooting

Follow the instructions in the ARIES® Package Insert for errors that occur during assay runs.

Contact Luminex Technical Support for instrument errors or malfunctions (e.g., “Top heater unresponsive”, “TEC(x) has an open thermistor”, or “Magnet home operation failed after retry”, etc.).

See section “*Luminex Technical Support*” on page 4 for contact information.

Appendix A: Shipping

Shipping

If a serious problem arises with the ARIES® M1 System, it may be necessary to return it to Luminex Corporation for repairs. If Luminex Technical Support directs you to return the ARIES® M1 System, the Technical Support Representative will provide you with all necessary information as well as give you a Return Material Authorization (RMA) number.

NOTE: Before the instrument is returned, the instrument must be decontaminated. For the decontamination procedure, see section “Maintenance” on page 86.

Shipment Checklist

Complete the following checklist, sign and date it, and return it with the ARIES® M1 System.

	Remove all samples from the instrument.
	Decontaminate the instrument. See “Maintenance” on page 86 for more information.

Was there damage to any used cassettes, or evidence of leaking inside the instrument?

	Yes
	No

Print Name: _____
Signature: _____
Company/Institution: _____
Date: _____
Instrument Serial No.: _____

Appendix B: Part Numbers

Hardware

Product Description	Part Number
Barcode reader with USB Type A cable	CN-0321-01
Magazine	CN-0339-01
Fuses (F5A, 250 V)	CN-0393-01
Sample Prep Tray	CN-0324-01
Cable, Power	CN-PXXX-01

* XXX is a country specific part number. For more information, contact Luminex Technical Support

Disinfecting Supplies

Product Description	Part Number
Thermo Fisher Scientific - Berkshire™ Durx™ 670 Cleanroom Wipers or equivalent	06-665-30B