

Luminex

Installation and User Manual | RUO

MAGPIX[®] Hardware

For Research Use Only. Not for use in diagnostic procedures.



© 2015 - 2017 Luminex Corporation. All rights reserved. No part of this publication may be reproduced, transmitted, transcribed, or translated into any language or computer language, in any form or by any means without prior express, written consent of Luminex Corporation.



Luminex Corporation

12212 Technology Blvd.

Austin, Texas 78727

U.S.A.

Technical Support

Telephone: 512-381-4397

North America Toll Free: 1-877-785-2323

International Toll Free: + 800 2939-4959

Email: support@luminexcorp.com

www.luminexcorp.com

MAGPIX® Installation and Hardware User Manual

PN 89-00002-00-434 Rev. D

August 2017



Luminex B.V.

Het Zuiderkruis 1

5215 MV 's-Hertogenbosch

The Netherlands

Luminex Corporation (Luminex) reserves the right to modify its products and services at any time. This guide is subject to change without notice. Although prepared to ensure accuracy, Luminex assumes no liability for errors or omissions, or for any damages resulting from the application or use of this information.

Luminex, xMAP, xPONENT, MAGPIX, and MagPlex are trademarks of Luminex Corporation, and registered in the U.S. and other countries.

All other trademarks, including ProClin®, Microsoft® Windows®, Sporocidin®, Cole-Parmer®, and Parafilm® M are trademarks of their respective companies.

This product, or use thereof, is covered, in whole or in part, or made by processes covered by one or more patents: www.luminexcorp.com/patents.

Standard Terms and Conditions for use of Instrument Product

By opening the packaging containing this instrument product (“Product”) or by using such Product in any manner, you are consenting and agreeing to be bound by the following terms and conditions. You are also agreeing that the following terms and conditions constitute a legally valid and binding contract that is enforceable against you. If you do not agree to all of the terms and conditions set forth below, you must promptly return the Product for a full refund prior to using them in any manner.

1. **Acceptance** - ALL SALES ARE SUBJECT TO AND EXPRESSLY CONDITIONED UPON THE TERMS AND CONDITIONS CONTAINED HEREIN, AND UPON BUYER'S ASSENT THERETO. NO VARIATION OF THESE TERMS AND CONDITIONS SHALL BE BINDING UPON LUMINEX CORPORATION (“LUMINEX”) UNLESS AGREED TO IN WRITING AND SIGNED BY AN AUTHORIZED REPRESENTATIVE OF LUMINEX.

For purposes of this agreement, “Seller” shall mean either Luminex, if the Product is purchased or otherwise acquired directly from Luminex, or a Luminex authorized reseller. Buyer, by accepting the Product, shall be deemed to have assented to the terms and conditions set forth herein, notwithstanding any terms contained in any prior or later communications from Buyer and whether or not Seller shall specifically or expressly object to any such terms.

2. **Warranties** - THIS WARRANTY IS APPLICABLE FOR PARTS AND SERVICE FOR LUMINEX INSTRUMENTS OR OTHERWISE ACQUIRED PURCHASED DIRECTLY FROM LUMINEX BY BUYER AND ONLY TO THE EXTENT SUCH INSTRUMENTS ARE LOCATED IN THE COUNTRIES LISTED ON LUMINEX'S WEBSITE LOCATED AT WWW.LUMINEXCORP.COM/COVERAGECOUNTRIES (“WARRANTY COVERAGE COUNTRIES”). LUMINEX MAKES NO WARRANTY, EITHER EXPRESS OR IMPLIED, WITH RESPECT TO PRODUCTS SOLD, DISTRIBUTED, LOCATED OR USED OUTSIDE OF THE WARRANTY COVERAGE COUNTRIES. PRODUCTS SOLD OUTSIDE OF THE WARRANTY COVERAGE COUNTRIES ARE SOLD ONLY ON AN “AS IS, WHERE IS” BASIS. NOTWITHSTANDING THE FOREGOING, LUMINEX SHALL PROVIDE BUYER A WARRANTY ON FIELD SERVICE PARTS (“FS-PARTS”) PROCURED FROM LUMINEX FOR MAINTENANCE OF LUMINEX INSTRUMENTS IN ALL COUNTRIES IN THE WORLD AND PER THE TERMS AND CONDITIONS HEREIN. TO THE EXTENT THAT THE FOREGOING DISCLAIMERS ARE INVALID OR UNENFORCEABLE UNDER THE LAWS OF ANY JURISDICTION, THE WARRANTY, DISCLAIMER, LIMITATION OF LIABILITY AND OTHER PROVISIONS SET FORTH BELOW SHALL THEREUPON BE EFFECTIVE TO THE FULLEST EXTENT PERMITTED BY APPLICABLE LAW.

Notwithstanding Buyer’s acceptance thereof, if Product is purchased or otherwise acquired directly from Luminex, Luminex warrants that for a period of twelve (12) months from date of delivery that: (i) the Product shall conform in all material respects with the Product Specifications provided by Luminex with the Product, and (ii) the FS-PARTS for the Products are free from defects in materials and workmanship. The warranty provided herein specifically excludes any software or hardware not provided by Luminex. If Product is purchased from a Luminex authorized reseller, any warranty obligations shall be provided in writing directly by such Luminex authorized reseller to Buyer. THIS WARRANTY IS EXCLUSIVE AND LUMINEX MAKES NO OTHER WARRANTY, EXPRESS OR IMPLIED, INCLUDING, WITHOUT LIMITATION, ANY IMPLIED WARRANTY OF MERCHANTABILITY, FITNESS FOR A PARTICULAR PURPOSE, OR NON-INFRINGEMENT. Seller's warranties made in connection with this sale shall not be effective if Seller has determined, in its sole discretion, that Buyer has misused the Product in any manner, has failed to use the Product in accordance with industry standards or practices, or has failed to use the Product in accordance with instructions, if any, furnished by Seller.

BUYER'S EXCLUSIVE REMEDY WITH RESPECT TO PRODUCT PROVED TO SELLER'S SATISFACTION TO BE DEFECTIVE OR NONCONFORMING SHALL BE REPAIR OR REPLACEMENT OF SUCH PRODUCTS WITHOUT CHARGE OR REFUND OF THE PURCHASE PRICE, IN SELLER'S SOLE DISCRETION, UPON THE RETURN OF SUCH PRODUCTS IN ACCORDANCE WITH SELLER'S INSTRUCTIONS BELOW. NEITHER SELLER NOR LUMINEX NOR ANY OF ITS AFFILIATES SHALL IN ANY EVENT BE LIABLE FOR INCIDENTAL, CONSEQUENTIAL OR SPECIAL DAMAGES OF ANY KIND RESULTING FROM ANY USE OR FAILURE OF THE PRODUCT, EVEN IF SELLER OR LUMINEX OR ITS AFFILIATE HAS BEEN ADVISED OF THE POSSIBILITY OF SUCH DAMAGES, INCLUDING, WITHOUT LIMITATION, LIABILITY FOR LOSS OF WORK IN PROGRESS, DOWN TIME, LOSS OF REVENUE OR PROFITS, FAILURE TO REALIZE SAVINGS, LOSS OF PRODUCTS OF BUYER OR OTHER USE OR ANY LIABILITY OF BUYER TO A THIRD PARTY ON ACCOUNT OF SUCH LOSS, OR FOR ANY LABOR OR ANY OTHER EXPENSE.

DAMAGE OR LOSS OCCASIONED BY SUCH PRODUCT, INCLUDING PERSONAL INJURY OR PROPERTY DAMAGE UNLESS SUCH PERSONAL INJURY OR PROPERTY DAMAGE IS CAUSED BY SELLER'S GROSS NEGLIGENCE.

In the event that the Product or an FS-PART fails to conform to the warranty set forth herein, during the warranty period: (i) Buyer shall notify Luminex in a timely manner in writing that such Product or FS-PART, as applicable, failed to conform and shall furnish a detailed explanation of any alleged nonconformity; (ii) Buyer, at its expense, will contact either Luminex or a Luminex trained service engineer to assess the issue and identify the defective Product or FS-PART, as applicable; and (iii) at Luminex's option and election, Buyer shall either return such nonconforming Product or FS-PART to Luminex (at its manufacturing facility or at a place designated by Luminex) or destroy such Product or FS-PART, as applicable, and provide Luminex with written certification of destruction. In the event that a Product or an FS-PART, as applicable, is returned to Luminex's manufacturing facility, Luminex may analyze such Product or FS-PART, as applicable, for nonconformities. In the event that Luminex determines that such Product or FS-PART, as applicable, is conforming, the Product or FS-PART, as applicable, shall be shipped to Buyer and Buyer shall be responsible for the payment for such Product or FS-PART, as applicable, and related shipping charges. In the event that Luminex determines that such Product or FS-PART, as applicable, is nonconforming, Luminex shall be responsible for the payment for such Product or FS-PART, as applicable, and related shipping charges. Except as expressly provided herein, Buyer shall not have the right to return a Product or FS-PART, as applicable, to Luminex without Luminex's prior written consent.

3. **Buyer's Use of Product** – Buyer shall not use this Product for any commercial purpose, including without limitation performance of testing services, unless expressly agreed to in writing by Luminex or as specifically authorized by Luminex through a Luminex authorized reseller. Buyer agrees that no rights or licenses under Luminex's patents shall be implied from the sale of the Product, except as expressly provided herein or as specifically agreed to in writing by Luminex, and Buyer does not receive any right under Luminex's patent rights hereunder. Buyer acknowledges and agrees that the Product is sold and licensed only for use with Luminex's beads or cassettes, as applicable. For quality control purposes, Buyer shall not use the product with any microspheres, sheath fluid, or cassettes other than the beads, sheath fluid, and cassettes authorized by Luminex. Buyer further acknowledges that the Product has not received clearance from the United States Food and Drug Administration or other federal, state or local regulatory agencies and has not been tested by Seller or Luminex for safety or efficacy in food, drug, medical device, cosmetic, commercial or any other use, unless otherwise stated on the Product label or in Seller's technical specifications or material data sheets furnished to Buyer. Buyer expressly represents and warrants to Seller that Buyer will use the Product in accordance with the Product label, if applicable, and will properly test and use any Product in accordance with the practices of a reasonable person who is an expert in the field and in strict compliance with the United States Food and Drug Administration and all applicable domestic and international laws and regulations, now and hereinafter enacted.

BUYER HEREBY GRANTS TO LUMINEX A NONEXCLUSIVE, WORLDWIDE, UNRESTRICTED, ROYALTY-FREE, FULLY PAID-UP LICENSE, WITH THE RIGHT TO GRANT AND AUTHORIZE SUBLICENSES, UNDER ANY AND ALL PATENT RIGHTS IN INVENTIONS COMPRISING MODIFICATIONS, EXTENSIONS, OR ENHANCEMENTS MADE BY BUYER TO THE PRODUCT OR TO THE MANUFACTURE OR USE OF THE PRODUCT ("IMPROVEMENT PATENTS"), TO MAKE, HAVE MADE, USE, IMPORT, OFFER FOR SALE OR SELL ANY AND ALL OF THE PRODUCT; EXPLOIT ANY AND ALL METHODS OR PROCESSES; AND OTHERWISE EXPLOIT IMPROVEMENT PATENTS FOR ALL PURPOSES. NOTWITHSTANDING THE FOREGOING, "IMPROVEMENT PATENTS" SPECIFICALLY EXCLUDES PATENT CLAIMS CONCEIVED AND REDUCED TO PRACTICE BY BUYER CONSISTING OF METHODS OF SAMPLE PREPARATION, THE COMPOSITION OF MATTER OF THE SPECIFIC CHEMISTRIES OF THE ASSAYS DEVELOPED BY BUYER AND METHODS OF PERFORMING THE ASSAYS (I.E., THE PROTOCOL FOR THE ASSAY).

Buyer has the responsibility and hereby expressly assumes the risk to verify the hazards and to conduct any further research necessary to learn the hazards involved in using the Product. Buyer also has the duty to warn Buyer's customers, employees, agents, assigns, officers, successors and any auxiliary or third party personnel (such as freight handlers, etc.) of any and all risks involved in using or handling the Product. Buyer agrees to comply with instructions, if any, furnished by Seller or Luminex relating to the use of the Product and to not misuse the Product in any manner. Buyer shall not reverse engineer, decompile, disassemble or modify the Product. Buyer acknowledges that Luminex retains ownership of all patents, trademarks, trade secrets and other proprietary rights relating to or residing in the Product and Buyer receives no rights to such intellectual property rights by virtue of its purchase of Product other than as expressly set

forth herein. Buyer shall have no right to use any trademarks owned or licensed to Luminex without the express written permission of Luminex.

4. **Buyer's Representations, Release and Indemnity** - Buyer represents and warrants that it shall use the Product in accordance with Paragraph 3, "Buyer's Use of Product," and that any such use of the Product will not violate any law, regulation, judicial order or injunction. Buyer agrees to release, discharge, disclaim and renounce any and all claims, demands, actions, causes of action and/or suits in law or equity, now existing or hereafter arising, whether known or unknown, against Seller and Luminex, and their respective officers, directors, employees, agents, successors and assigns (collectively the "Released Parties"), with respect to the use of the Product. Buyer agrees to indemnify and hold harmless the Released Parties from and against any suits, losses, claims, demands, liabilities, costs and expenses (including attorney, accounting, expert witness, and consulting fees) that any of the Released Parties may sustain or incur as a result of any claim against such Released Party based upon negligence, breach of warranty, strict liability in tort, contract or any other theory of law or equity arising out of, directly or indirectly, the use of the Product or by reason of Buyer's failure to perform its obligations contained herein. Buyer shall fully cooperate with the Released Parties in the investigation and determination of the cause of any accident involving the Product which results in personal injury or property damage and shall make available to the Released Parties all statements, reports, recordings and tests made by Buyer or made available to Buyer by others.
5. **Patent Disclaimer** – Neither Seller nor Luminex warrants that the use or sale of the Product will not infringe the claims of any United States or other patents covering the Product itself or the use thereof in combination with other products or in the operation of any process.

89-30000-00-186 Rev E

Table of Contents

Chapter 1: About this Manual

Warnings and Notes	1
Symbols	1

Chapter 2: Safety and Regulatory Considerations

Description	3
Regulatory Labels and Warnings	3
Testing and Certifications	4
Safety Practices	5
General	5
Mechanical	5
Electrical	5
Indicator Light	5
Biohazard	5
Electromagnetic Compatibility	6
Barcode Reader Laser	6
Heat	6
Fluids	6
Decontamination Procedure	7
Disposal of Instrument	7

Chapter 3: Installation Procedure

Installation Diagram	10
Unpacking and Assembling the PC	11
Unpacking and Assembling MAGPIX®	11
Connecting the Components	13
Preparing the MAGPIX® for First Use	14
Removing the Shipping Plug	15
Installing the Sample Probe	17
Installing the Drive Fluid	20
Powering Up MAGPIX®	22
Initial Startup	23
Adjusting the Sample Probe Height	24
Revive After Storage Routine	25
Calibration - Verification	25
Shipping Checklist	26

Chapter 4: Technical Overview

How MAGPIX® Operates	28
System Components	30
Software	30
Hardware	31
Reagents	31
Subsystems	32
Electronic Subsystem	32
Fluidics Subsystem	33
Mechanical Subsystem	39

Optical Subsystem	42
Recommended Additional Equipment	42
Uninterruptible Power Supply (UPS) or Surge Protector	42
Printer	43
Barcode Labels	43
Vortex	43
Bath Sonicator	43
System Specifications	43
General Specifications	43
Environmental Conditions	43
Electronics	44
Optics	44
Fluidics	44
Microtiter Plates	44
Microspheres	44

Chapter 5: Operational and Maintenance Procedures

General Maintenance Precautions	45
Accessing the Side Compartment	45
Daily Procedures	46
Initializing MAGPIX®	46
Verifying MAGPIX®	46
Maintaining Fluids	46
Shutting Down MAGPIX®	47
Weekly Procedures	47
Cleaning MAGPIX®	47
Cleaning the Sample Probe	47
Performing a Visual Inspection	48
Calibrating and Verifying MAGPIX®	48
Removing Clogs	49
Monthly Procedures	49
Cleaning the Exterior Surfaces	49
Semi-Annual Procedures	49
Maintaining Air Filters	49
Replacing the Syringe Seal	51
Annual Procedures	52
Replacing the Sample Probe Tube	52
Replacing the Drive Fluid Filter	54
As Needed Maintenance	55
Replacing Fuses	55
Maintenance Logs	56
Short Term Maintenance - One Week	57
Long Term Maintenance - One Year	57

Chapter 6: Troubleshooting Procedures

Overview	58
Power Supply Problems	58
Communication Problems	59

Table of Contents

- Clogs59
- Fluid Leaks59
- Sample Probe Problems60
- Calibration Failure61
- Verification Failure62
- Acquisition Failure62
- Carryover Problems63
- Bead Detail Irregularities63
- Technical Support65
- Storing MAGPIX®66
- Preparing MAGPIX® for Use After Storage66
- Preparing MAGPIX® for Shipping67
- Shipment Checklist67
- Hardware68
- Reagents68

Chapter 1: About this Manual

Warnings and Notes

The following informational notes and warnings appear as necessary in this manual.

NOTE: This message is used to provide general helpful information. No safety or performance issues are involved.



CAUTION: This message is used in cases where the hazard is minor or only a potential hazard is present. Failure to comply with the caution can result in hazardous conditions.



WARNING: This message is used in cases where danger to the operator or to the performance of the instrument is present. Failure to comply with the warning can result in incorrect performance, instrument failure, invalid results, or hazard to the operator.









DANGER: This message is used in cases where significant risk of serious injury or death is present

Symbols

You will encounter these symbols throughout this manual. They represent warnings, conditions, identifications, instructions, and regulatory agencies.

Key to Symbols

Symbol	Meaning	Symbol	Meaning	Symbol	Meaning
	Biological risks		Caution, hot surface		Caution
	Hand Crush/ Force From Above		Burn Hazard / Hot Surface		Caution, possibility of electric shock
	Warning; Laser Beam To warn of a laser beam		Puncture/Pinch Point Warning		Consult instructions for use
	Protective earth; protective ground		Alternating Current		Model or Catalog Number
	Serial number		Batch Code		Fuse
	Use-by date		Temperature Limit		WEEE Symbol

Symbol	Meaning	Symbol	Meaning	Symbol	Meaning
	For Research Use Only. Not for use in Diagnostic Procedures		Manufacturer / Date of manufacture		Stand-by Power on/off
	TÜV SÜD NRTL Certification Mark		MET Mark		Conformite Europeenne (EU CE Marking of Conformity) CE conformity marking
	Authorized representative in the European Community				

Chapter 2: Safety and Regulatory Considerations

Become familiar with the safety information in this chapter before using MAGPIX®. This system contains electrical and mechanical components that, if handled improperly, are potentially harmful. In addition, biological hazards can be present during system operation. Therefore, Luminex recommends that all system users become familiar with the specific safety advisories below in addition to adhering to standard laboratory safety practices. Do not perform procedures on MAGPIX that are not specifically described in this manual, unless you are directed to do so by Luminex “*Technical Support*”, on page 66.

Description

The Luminex® MAGPIX® system is a life science research multiplex test system intended to measure and sort multiple signals generated in an assay from a biological sample. The MAGPIX system is for research use only and is not for use in diagnostic procedures. The MAGPIX system is for indoor laboratory and professional use only.

Regulatory Labels and Warnings

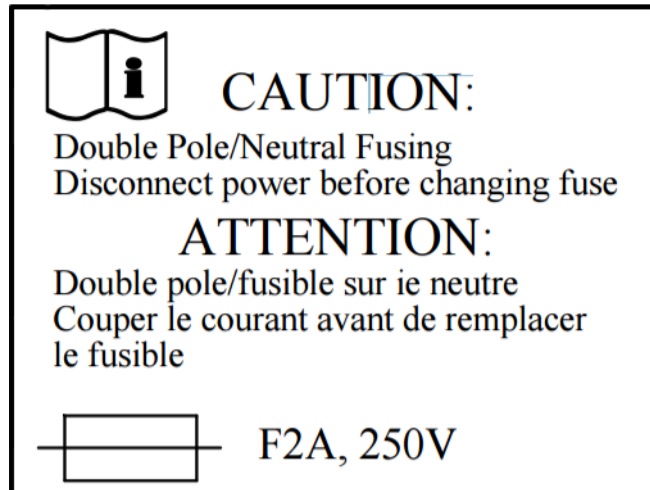

The following fuse caution label appears on MAGPIX®.

FIGURE 1. Fuse Caution Label



A voltage label appears on the back of MAGPIX. The label displays the MAGPIX serial number, model number, power requirements, and manufacturer’s information.

FIGURE 2. Serial Number and Voltage Label

Luminex Corporation
12212 Technology Blvd.
Austin, Texas 78727
USA, 2016-10-20 🏢
 **Model: MAGPIX**
 **MAGPX16294725**
100-120V~, 2.0A 50/60 Hz or
200-240V~, 1.0A 50/60 Hz

A label with legal information appears on the MAGPIX.

FIGURE 3. Legal Label

BY OPENING THE PACKAGING CONTAINING THIS UNIT OF LUMINEX INSTRUMENTATION OR USING THIS UNIT OF LUMINEX INSTRUMENTATION IN ANY MANNER, YOU ARE CONSENTING AND AGREEING TO BE BOUND BY THE FOLLOWING TERMS AND CONDITIONS AND THE TERMS AND CONDITIONS SET FORTH IN THE END USER LICENSE AGREEMENT FOR THE LUMINEX SOFTWARE INCLUDED WITH THIS UNIT. YOU ARE ALSO AGREEING THAT ALL SUCH TERMS AND CONDITIONS CONSTITUTE A LEGALLY VALID AND BINDING CONTRACT THAT IS ENFORCEABLE AGAINST YOU. IF YOU DO NOT AGREE TO ALL OF SUCH TERMS AND CONDITIONS, YOU MUST PROMPTLY RETURN THIS UNIT OF LUMINEX INSTRUMENTATION FOR A FULL REFUND PRIOR TO USING IT IN ANY MANNER.

NO RIGHTS OR LICENSES UNDER ANY OF LUMINEX'S PATENTS ARE GRANTED OR SHALL BE IMPLIED FROM THE SALE OF THIS UNIT OF LUMINEX INSTRUMENTATION OR LICENSE OF LUMINEX SOFTWARE TO YOU, THE PURCHASER, AND YOU DO NOT RECEIVE ANY RIGHT UNDER LUMINEX'S PATENT RIGHTS BY VIRTUE OF YOUR PURCHASE OF LUMINEX INSTRUMENTATION OR LICENSE OF LUMINEX SOFTWARE. YOU AGREE THAT THE LUMINEX INSTRUMENTATION AND LUMINEX SOFTWARE ARE SOLD ONLY FOR USE WITH FLUORESCENTLY LABELED MICROSPHERE BEADS AUTHORIZED BY LUMINEX AND YOU MAY OBTAIN A ROYALTY-FREE LICENSE UNDER LUMINEX'S PATENTS, IF ANY, TO USE THIS UNIT OF LUMINEX INSTRUMENTATION WITH FLUORESCENTLY LABELED MICROSPHERE BEADS AUTHORIZED BY LUMINEX BY PURCHASING BEADS AUTHORIZED BY LUMINEX AND REGISTERING THIS UNIT OF LUMINEX INSTRUMENTATION WITH LUMINEX IN ACCORDANCE WITH THE INSTRUCTIONS ACCOMPANYING THE LUMINEX INSTRUMENTATION.

BUYER SHALL NOT USE THIS PRODUCT FOR ANY COMMERCIAL PURPOSE, INCLUDING WITHOUT LIMITATION PERFORMANCE OF TESTING SERVICES, UNLESS EXPRESSLY AGREED TO IN WRITING BY LUMINEX OR AS AUTHORIZED BY LUMINEX THROUGH A LUMINEX DISTRIBUTOR.

Testing and Certifications

The MAGPIX® has been tested and complies with the safety requirements for the United States and Canada. One of the following agency marks will be on the instrument.

FIGURE 4. Safety Label



In addition, MAGPIX complies with European Union (EU) safety requirements and therefore can be marketed in the Europe Single Market. The following European Union compliance label appears on the back of the MAGPIX instrument.

FIGURE 5. European Union Compliance Label



Safety Practices

In any situation in which you encounter this symbol, consult this manual or other Luminex® documentation to determine the nature of the potential hazard and any necessary actions you must take.



CAUTION: The protection provided by the equipment can be impaired or the warranty voided if the Luminex MAGPIX® system is used in a manner not specified by the instructions or by Luminex Corporation.

General



CAUTION: Keep the front access doors closed and latched during normal operations. Always observe standard laboratory safety practices.

Mechanical



WARNING: MAGPIX® has parts that move during operation. Risk of personal injury is present. The moving parts present puncture and pinching hazards. Keep your hands and fingers away from the plate carrier slot, syringe pump, and sample probe during operation. The plate carrier ejects without warning, especially during multi-plate batches. Observe all warnings and cautions. Keep the access door closed and latched during normal operations.

Electrical



WARNING: Do not perform any maintenance or cleaning of the electrical components in the system, with the exception of replacing fuses.

Observe the fuse caution stated on the fuse caution label. Be aware of the voltage of the instrument. See “*Regulatory Labels and Warnings*”, on page 3 for the label.

Power cords must be replaced with cords of the same type and ratings as originally provided. Contact Luminex “*Technical Support*”, on page 66 for correct replacement power cords.

Indicator Light

The lights inside the front panel of MAGPIX® indicate the status of the system and are harmless. The blue light-emitting diodes (LEDs) do not emit light in the UV spectrum.

Biohazard

Human and animal samples can contain biohazardous infectious agents. To avoid pressurization problems, the waste fluid container is vented, so beware of biohazardous aerosol material.



WARNING: Where exposure to potentially biohazardous material, including aerosol, exists, follow appropriate biosafety procedures and use personal protective equipment (PPE). PPE includes gloves, gowns, laboratory coats, face shields or mask and eye protection, respirators, and ventilation devices. Observe all local, state, federal and country-specific biohazard handling regulations when disposing of biohazardous waste material.

Electromagnetic Compatibility

MAGPIX® complies with the emission and immunity requirements described in IEC 61326-1. The electromagnetic environment should be evaluated prior to operation.



WARNING: Do not use this instrument in close proximity to sources of strong electromagnetic radiation, for example, unshielded intentional RF sources, as these can interfere with the proper operation.



WARNING: Always handle MAGPIX according to Luminex® instructions to avoid any possible interference from its electromagnetic fields.

Barcode Reader Laser

The accessory barcode reader is classified under FDA 21 CFR 1040.10 and 1040.11 as a Class II laser product. In accordance with IEC 60825-1, the accessory barcode reader is classified as Class 2.

The barcode reader laser presents a potential hazard to eyesight.



WARNING: Do not stare into the barcode reader beam or shine it into other people's eyes.

Heat

The heater plate, used to warm the plate carrier of the Y platform, can be heated between 35°C and 60°C.



CAUTION: Do not use the heater plate as an incubator. The purpose of the heater plate is to maintain the temperature of the microtiter plate while the plate is in the MAGPIX® instrument. Monitor the heater plate temperature while it is in use. If the heater plate overheats, discontinue use and contact Luminex “*Technical Support*”, on page 66.



WARNING: The heater plate of the MAGPIX plate carrier can be hot and will cause personal injury if touched. Do not touch the heater plate.

Fluids

This instrument contains fluids. In the event of a fluid leak, turn off all power to the system and disconnect all power cords. The on/off switch is not a method of disconnection; the power cord must be removed from the outlet. Contact Luminex “*Technical Support*”, on page 66 for further information.



DANGER: Do not operate the instrument in the presence of leaking fluid.



WARNING: Reagents can contain sodium azide as a preservative. Sodium azide is toxic and can also react with lead and copper plumbing to form highly explosive metal azides. On disposal, flush drains with a generous amount of cold water to prevent azide build-up. Consult the manual guideline “*Safety Management No. CDC-22, Decontamination of Laboratory Sink Drains to remove Azide Salts*”.

Decontamination Procedure

Occasions will arise that require you to decontaminate the entire MAGPIX® instrument. If you must decontaminate the instrument, sanitize the accessible surfaces and the internal fluidics system. This is particularly important when biohazardous samples have been run.



WARNING: Wear appropriate personal protective equipment when handling parts that come into contact with potentially biohazardous samples.

To decontaminate MAGPIX:

1. Remove all specimens and all Luminex® MAGPIX reagents. Leave distilled water and household bleach solution diluted to 10% to 20% in water in the off-plate reagent block of the system.
2. Use the software to run a sanitize command with the diluted (10% to 20%) household bleach solution followed by two wash commands with distilled water.
3. Empty the off-plate reagent block and the waste container and clean each with a 10% to 20% bleach solution followed by a distilled water rinse.
4. Turn off MAGPIX and unplug the power cord.
5. Clean all exterior surfaces with mild detergent followed by a household bleach solution diluted to 10% to 20%.
6. Open the side access door of the instrument.
7. Clean all accessible surfaces with detergent followed by the household bleach solution (10% to 20%).

Disposal of Instrument



Within the European Union, the Waste Electrical and Electronic Equipment Directive requires that you properly dispose of electrical and electronic equipment when it reaches its end of life.

If you are disposing of a Luminex® MAGPIX® instrument, decontaminate the system. Refer to the “*Decontamination Procedure*”, on page 7 for more information. Next, contact Luminex “*Technical Support*”, on page 66 for a Return Material Authorization (RMA) number at +1-512-381-4397 (outside of the U.S.). Return the equipment to the following Luminex location:

Luminex Corporation

12201 Technology Blvd., Suite 130

Austin, Texas 78727, USA

For information about disposal of MAGPIX outside of the European Union, contact Luminex “*Technical Support*”, on page 66. For information about disposal of the barcode scanner, PC, or monitor, refer to the manufacturer documentation.

Chapter 3: Installation Procedure

Before handling or unpacking MAGPIX®, make certain that the selected site is appropriate. Refer to the “*Installation Diagram*”, on page 10 for handling and site installation requirements and detailed dimensions of MAGPIX.

Check for these requirements:

- Indoors
- Operating temperature of 15°C to 35°C (59°F to 95°F)
- Operating relative humidity of 20% to 80%, noncondensing
- Operating altitude up to 2400 m (7874 ft) above mean sea level
- Available electrical power outlet with protective earthing and easy accessibility
- Available area of approximately 3' X 3' (91.44 cm), including a 2" (5.08 cm) clearance between the back of MAGPIX and any wall or vertical surface.
- Stable, level surface

MAGPIX arrives in a large, corrugated cardboard over pack on skids.

FIGURE 6. The MAGPIX® Overpack



CAUTION: This overpack is too heavy to be lifted by one person (approximately 119 lbs (53.97 kg), a three-person lift) and should be moved mechanically. Be careful the overpack is not punctured during any necessary moving.

Within the overpack are separate cartons for the PC, the monitor, the 2-pack of Drive Fluid, and the MAGPIX instrument. In addition, a divided tray contains the cables, CDs, and printed material. For the complete list of contents, see the “*Shipping Checklist*”, on page 27.

FIGURE 7. Inside the Overpack



1.	PC carton
2.	Monitor carton
3.	MAGPIX® carton
4.	Accessory tray (monitor stand and Drive Fluid cartons are underneath)

Each individual carton can be handled by one person. The MAGPIX carton and the PC carton each weigh less than 40 pounds (18.14 kg).

Unpacking and Assembling the PC

Begin the installation process with the PC. The computer and monitor are in the boxes at the end of the overpack; the monitor stand is in a box underneath the accessory tray.

The computer and monitor boxes include all the necessary cords and peripheral devices as well as complete installation instructions. Follow those instructions to set up the PC.

To set up the PC:

1. Remove the three boxes containing PC components from the overpack.
2. Assemble the components using the instructions provided by the PC vendor.

FIGURE 8. The Assembled PC



Unpacking and Assembling MAGPIX®

To install the MAGPIX® instrument:

1. Remove the MAGPIX carton from the overpack.

FIGURE 9. Removing the MAGPIX® Carton



The MAGPIX instrument is inside a plastic bag and surrounded by foam inserts attached to a corrugated cardboard insert.

FIGURE 10. The MAGPIX® Carton, Opened



2. Remove MAGPIX from its carton by pulling on the handles that extend from the cardboard insert.

NOTE: Luminex recommends to have another person hold down the carton while you pull out the MAGPIX.

FIGURE 11. Pulling MAGPIX® from its Carton



3. Put the instrument on a stable, flat surface. This will require two people.
4. Fold down the cardboard panels from each side of the instrument.

FIGURE 12. Removing the Packing Materials

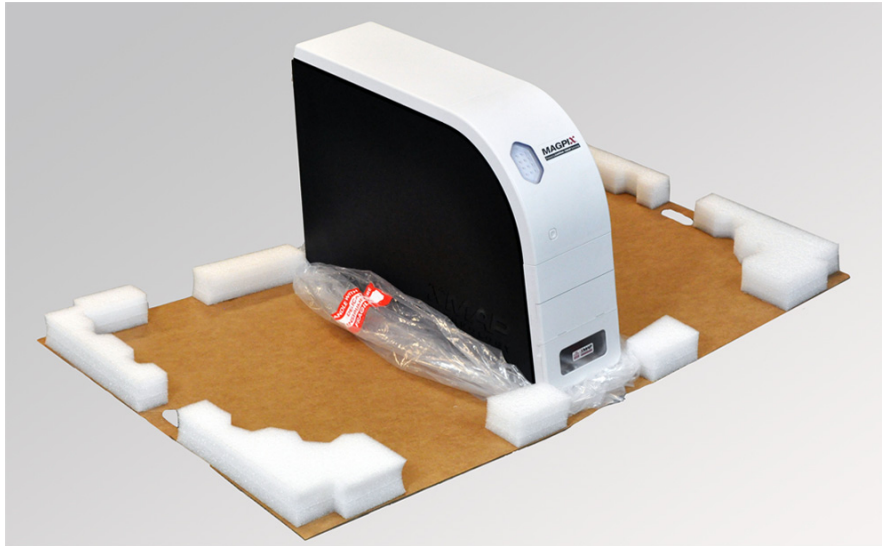

5. Pull the plastic bag down from the top.
6. Place MAGPIX onto a lab bench or other flat, stable surface. This will require two people.

Before proceeding with the installation, check the contents of the over pack with the “*Shipping Checklist*”, on page 27 and make certain you can locate all listed items. Check contents to make certain no damage has occurred during shipping. If anything is missing or damaged, contact Luminex “*Technical Support*”, on page 66.

Connecting the Components

To connect the components:

1. Locate the cords in the accessory tray of the overpack.

FIGURE 13. Power Cord and USB Cable



2. Plug the power cord into the back of the instrument.
3. Connect the USB cable to the PC and to the connector labeled P1 on the back of MAGPIX®.

FIGURE 14. Power Cord and USB Cable Connected



4. Connect the barcode scanner (if ordered) to the computer, to a USB port on either the front or back.

FIGURE 15. All Components Connected



Preparing the MAGPIX® for First Use

Preparing MAGPIX® for first use includes removing the shipping plug, installing the Drive Fluid, and installing the sample probe.

Removing the Shipping Plug

Inside the side access door of MAGPIX®, a shipping plug holds the sample probe assembly in place. Use the door access tool included in the accessory tray to open the side access door and remove the plug.



CAUTION: MAGPIX should not be plugged into a power source when you open this compartment.

To open the side access door and remove the shipping plug:

1. Locate the door access tool in a small plastic bag in the accessory tray of the overpack.

FIGURE 16. Door Access Tool



2. Insert the tool in the side access door latch and turn it one-quarter turn clockwise.

FIGURE 17. Door Access Tool Inserted and Turned



3. Slide the door to the right.

FIGURE 18. Sliding Open the Door

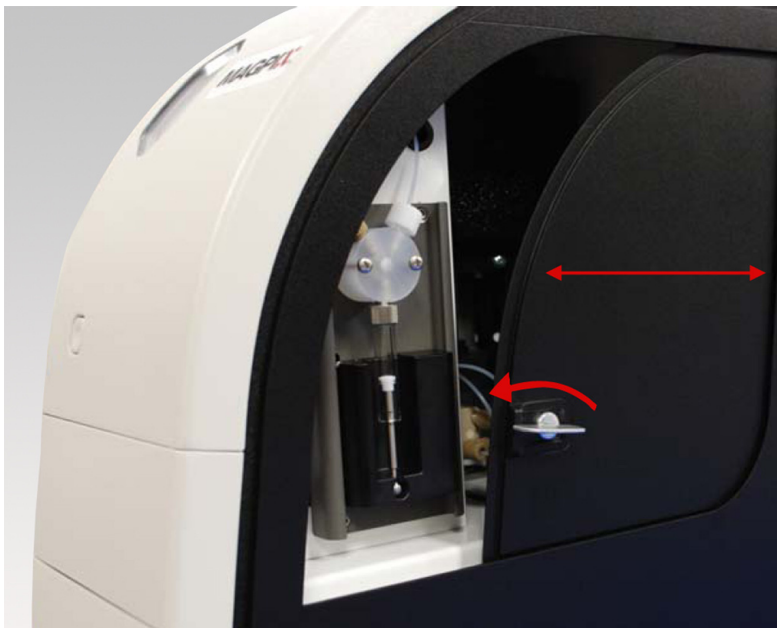

4. Raise the probe assembly and locate the shipping plug.

FIGURE 19. The Shipping Plug in Position

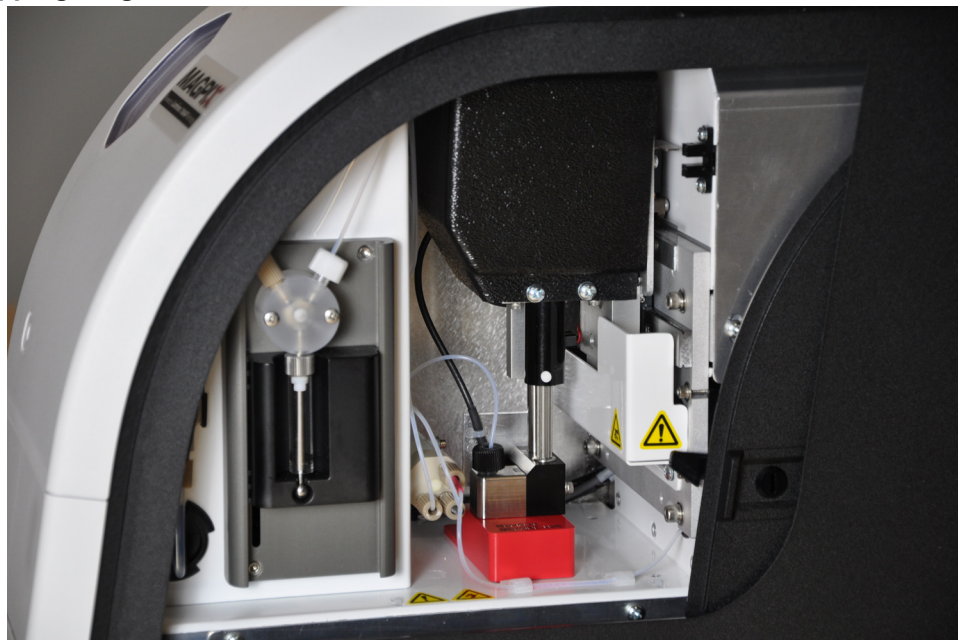

5. Pull the probe holder up, then, holding MAGPIX on the top with one hand to stabilize it, firmly push the probe assembly away from you with your other hand. Be prepared to use some strength.

FIGURE 20. Pushing the Probe Assembly

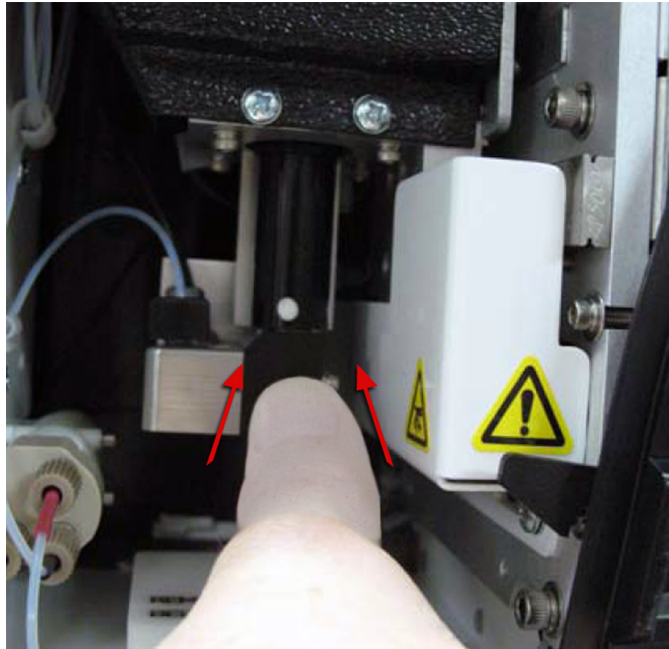

6. With the probe assembly out of the way, lift out the shipping plug.

FIGURE 21. Removing the Shipping Plug



Installing the Sample Probe

MAGPIX® comes with two sample probes, but the probe is not pre-installed.

To install the sample probe:

1. Locate the sample probe, which is shipped in a tube in the accessory tray.

FIGURE 22. Sample Probe and Container

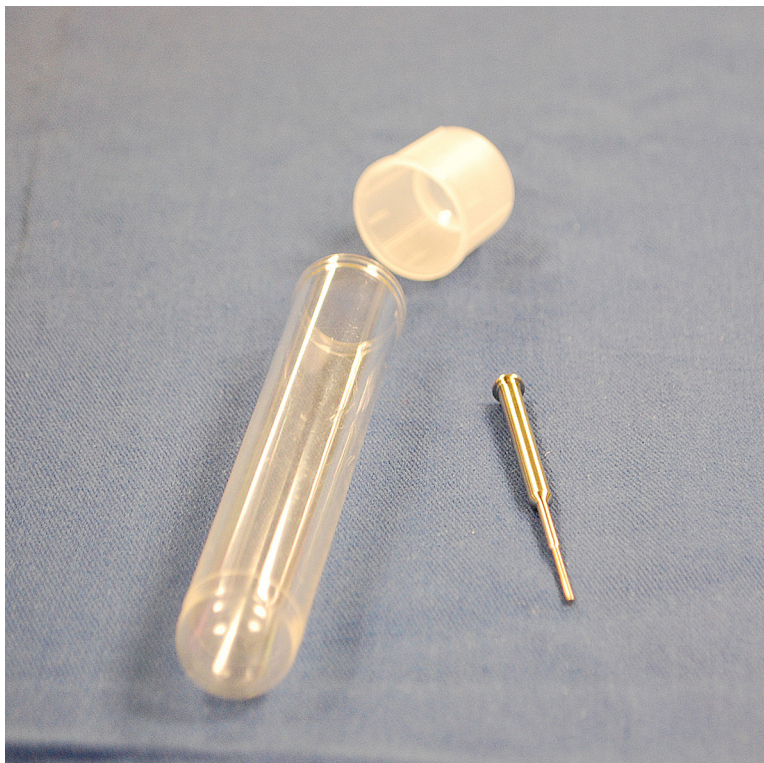

2. Pull the probe assembly toward you and push it down.
3. Completely unscrew the probe fitting on top of the probe holder by turning it counterclockwise.

FIGURE 23. Unscrewing the Probe Fitting

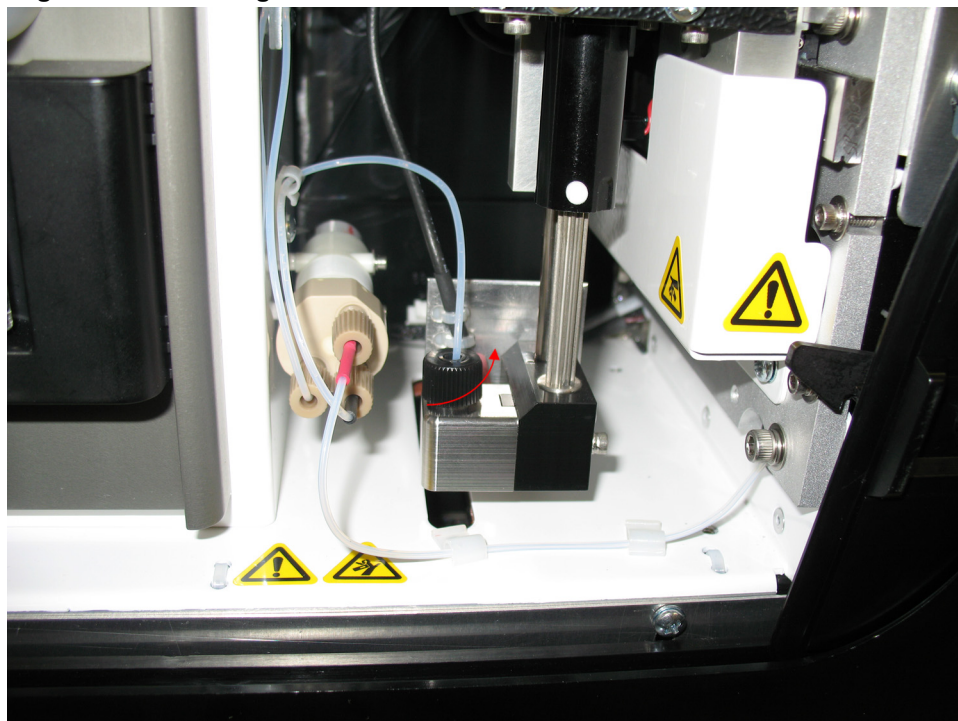

- Put the probe into the opening left by the probe fitting. It should slip down and catch at the bottom of the opening.

FIGURE 24. Inserting the Sample Probe

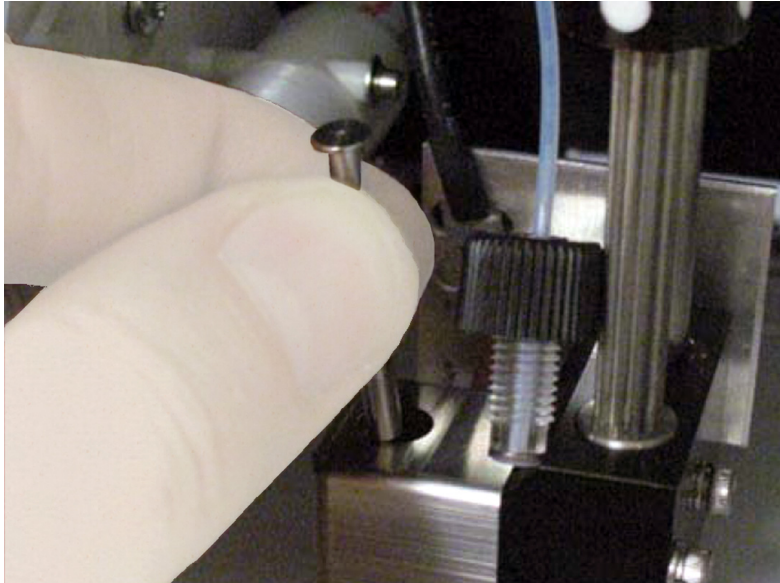

- Reinstall the probe fitting, tightening it until it clicks into place.

FIGURE 25. The Sample Probe in Position

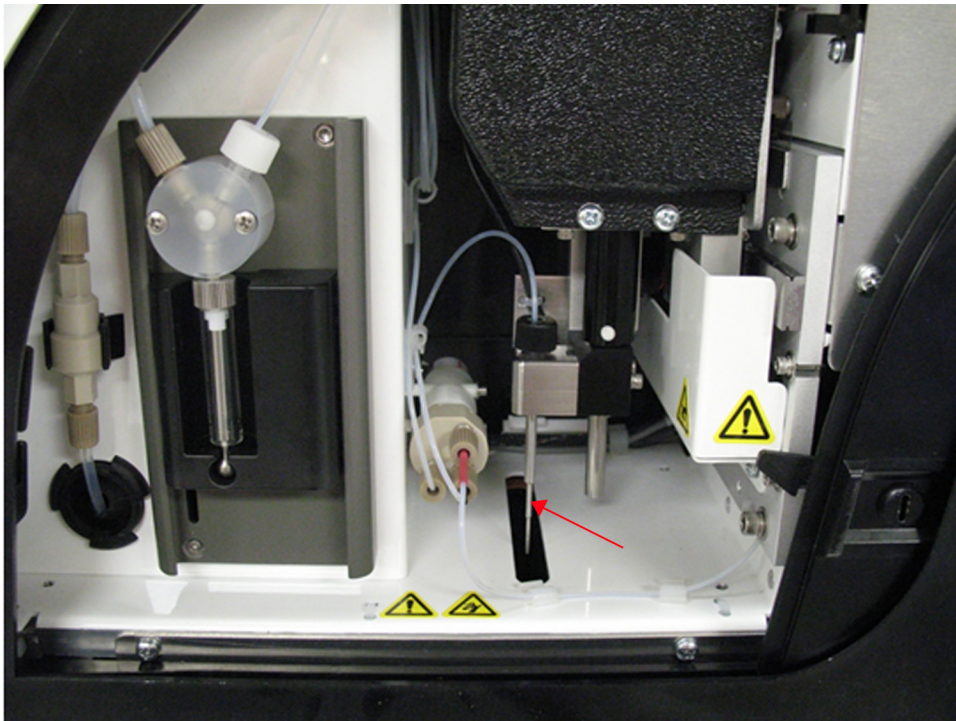

- Close and latch the side access door.

Installing the Drive Fluid

The overpack includes a carton containing two containers of Drive Fluid. Open the carton and remove one container to install in the instrument.

To install the Drive Fluid container:

1. Locate the carton of Drive Fluid containers.

FIGURE 26. Drive Fluid Carton and Container



2. Open the carton and remove a container of Drive Fluid.

3. Open the door of the fluid compartment on the front of MAGPIX®.

FIGURE 27. Fluid Compartment



4. Pull the Drive Fluid tube and plug (1) in the left side of the fluid compartment forward until it extends outside the compartment. Pull it to the left to allow room to insert the Drive Fluid container.

FIGURE 28. Pulling out the Drive Fluid Tube and Plug



5. Insert the Drive Fluid container half way into the fluid compartment opening and remove the seal.

FIGURE 29. Removing the Seal



6. Connect the Drive Fluid tube and plug to the opening on the top of the Drive Fluid container.
7. Connecting the Tube and Plug to the Container Opening

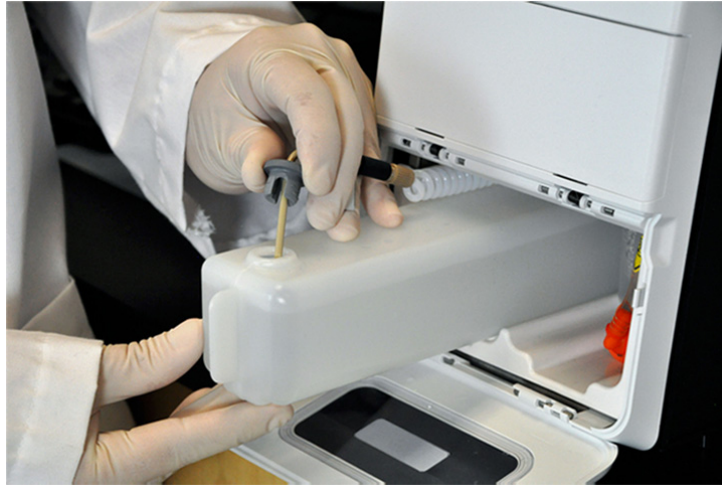

8. Slide the container into the tray on the left side of the fluid compartment. The container tray is constructed to hold the container in place.

FIGURE 30. Sliding in the Drive Fluid Container

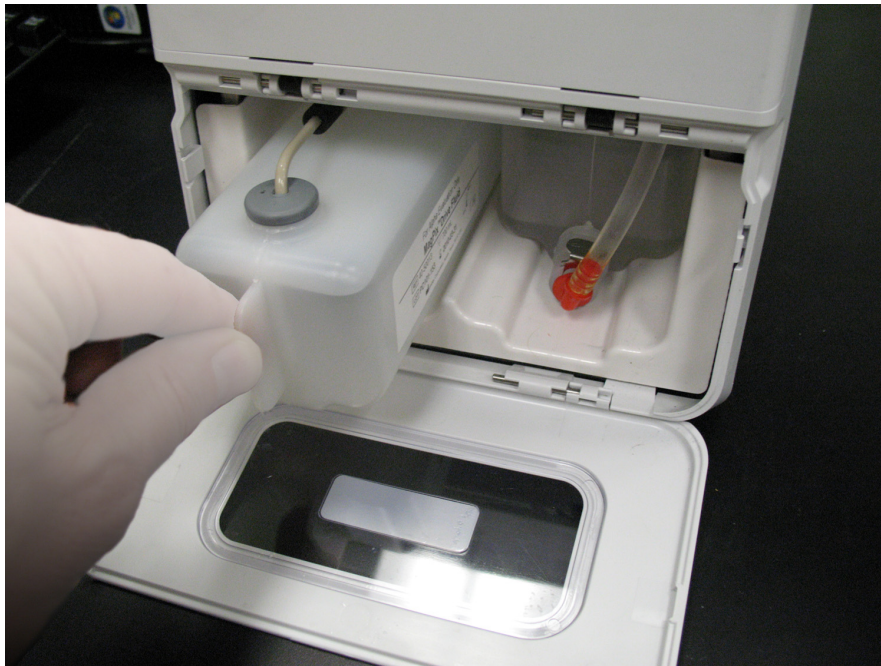

9. After the container is fully inserted, check the valve on the front of the waste fluid container to make certain it is securely attached and close the door of the fluid compartment.

Powering Up MAGPIX®

MAGPIX® has two on/off switches: a hard power switch and a soft power switch. To power on MAGPIX:

1. Plug the power cord from the back of the instrument into a power outlet.

NOTE: Luminex recommends the use of a surge protector or UPS device with MAGPIX. For more information, see *“Uninterruptible Power Supply (UPS) or Surge Protector”*, on page 42.

2. Turn on the hard power switch (1). This is the toggle switch at the lower right corner of the back of MAGPIX.

NOTE: The hard power switch controls flow of power to the instrument.

FIGURE 31. Hard Power Switch

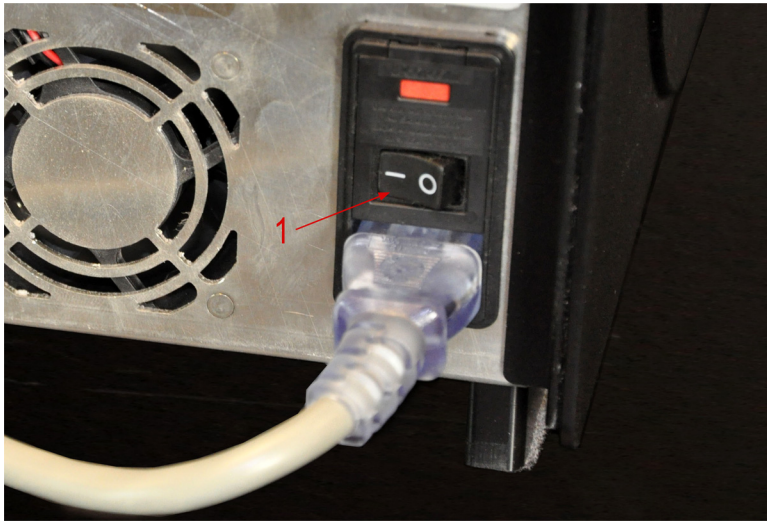

3. When you are ready to begin testing, turn on the soft power switch (2) on the front of MAGPIX. The blue LED in the hexagonal window lights up as confirmation that the power is on. MAGPIX requires approximately 45 seconds to start up.

NOTE: The soft power switch activates and deactivates the unit.

FIGURE 32. Soft Power Switch



4. After MAGPIX is powered on, use the software to eject the tray carrier to put the off-plate reagent block in place.

Initial Startup

When you turn on the system for the first time, perform the following procedures.

1. Adjust the Sample Probe Height
2. Revive After Storage (Luminex®) Routine
3. Calibration/Verification

Adjusting the Sample Probe Height

Adjust the sample probe height to ensure that the probe drops far enough into the well to acquire sample.

NOTE: Ensure that there is no liquid in the wells or reservoirs before adjusting the sample probe height.

1. On the **Home** page, click **Probe and Heater** under **Daily Activities**. The **Probe & Heater** tab opens.
2. Use well **D6** (this is the center of a standard 96-well plate).
3. Ensure that the well location is selected on the plate image. A green pin marks the selected well.
4. Based on the type of plate you are using, place alignment disks or an alignment sphere in the well.
 - For a standard 96-well plate - none
 - For a Filter-bottom plate - two 5.08 mm disks
 - For a Mylar-bottom plate - two 5.08 mm disks
 - For a conical (v-shaped) plate - one sphere
5. Click **Eject** to eject the plate carrier.
6. Place the off-plate reagent block on the plate carrier. Make sure it is well seated so that it clips into place.
7. Place a strip well (provided with the Calibration and the Performance Verification kit) in the off-plate reagent block.
8. In the **Strip Wells** section, click **SD1**.
9. Verify that the reservoir is empty.
10. In the **Reservoir** section, click well **RB1**.
11. Verify that the plate is not warped. Warped plates can lead to incorrect probe height adjustment.
12. Place the plate on the plate carrier with well A1 positioned as indicated on the plate carrier.
13. Click **Retract** to retract the plate carrier.
14. Type a name for the plate in the **Plate Name** box.
15. Click **Auto Adjust Height**. The probe automatically adjusts itself to the locations you selected.

NOTE: The probe height is automatically set to 0.98 mm. The probe automatically adjusts this distance from the bottom of the plate, or calibration disks or spheres.

16. Click **Eject** to eject the plate holder. If you used alignment disks or spheres, remove them from the plate.

NOTE: When you adjust and save the probe height settings for all three areas under a plate name, all areas retain the adjustment.



WARNING: Correct sample probe height is critical to successful sample acquisition and calibration. Problems with the sample probe height can lead to fluid leaks and inhibit sample acquisition.



CAUTION: Ensure that the probe height is set correctly before calibrating the system.

FIGURE 33. Sample Probe Height Adjustment



Revive After Storage Routine

NOTE: The **Revive After Storage** routine is necessary when the system runs for the first time and when the system has been idle for more than a week.

After you have adjusted the sample probe height, run the **Revive After Storage (Luminex)** routine.

1. Open the **Maintenance** page, then the **Cmds & Routines** tab.
2. Select **Revive After Storage (Luminex)** from the **Routine Name** drop-down list. The **Revive After Storage** routine performs the following commands:
 - Prime
 - Rinse
 - Alcohol Flush
 - Rinse
3. Add 70% isopropanol or 70% ethanol to reservoir **RB1** on the off-plate reagent block as indicated on the **Cmds & Routines** tab.

NOTE: The rinse reservoir (RD1) should be empty.

4. Click **Retract**.
5. Click **Run**.

After the **Revive After Storage** routine is complete, run the **System Initialization** routine.

Calibration - Verification

Calibration normalizes the settings for the system and ensures optimal and consistent microspheres classification. Verification uses system controls to ensure that the analyzer is functioning properly with current calibration settings.

1. On the **Home** page, click **System Initialization** under **Daily Activities**. The **Auto Maint** tab opens.
2. Click the **Calibration/Verification** option under **Automated Maintenance Options** section.

3. Import the **Calibration Kit** lot information from the CD provided with the kit or select the appropriate kit from the drop-down menu if the kit information has been preloaded.

NOTE: See the “*Adding or Importing CAL and VER Kit Information*”, on page 26 section on how to import the kit.

4. Import the **Performance Verification Kit** lot information from the CD provided with the kit or select the appropriate kit from the drop-down menu if the kit information has been preloaded.

NOTE: See the “*Adding or Importing CAL and VER Kit Information*”, on page 26 section on how to import the kit.

5. Vortex the xMAP® calibrator, verification, and fluidics containers at a medium speed for approximately 10 seconds to ensure homogeneity. Do not dilute xMAP calibrator, verification, or fluidics agents.
6. Click **Eject** on the status bar.

NOTE: To ensure that you get the necessary bead count, invert the calibrator and verifier vials perpendicular to the strip well as you add drops to the wells. This ensures that the maximum fluid drop size is dispensed into the wells.

7. Add 6 drops of each reagent into the designated well.
8. Verify that reservoir RB1 is 3/4 filled with 70% isopropanol or ethanol.

NOTE: The rinse reservoir (RD1) should be empty.

9. Click **Retract**.
10. Click **Run**.

Adding or Importing CAL and VER Kit Information

You can add CAL and VER Kit information from the **Home** page.

To add or import CAL and VER kit information:

1. Load the CAL/VER CD (provided with the kit) on the computer.
2. On the **Home** page, click **System Initialization**.
3. Click **Import Kit** at the bottom right side of the window. The **Import Calibration** or **Performance Kit** dialog box opens.
4. Select **Locate the CD** in the appropriate drive and select the *.mpx folder and click **Open**.
5. Select the *.ixl file and click **Open**.
6. Click **OK**.

Shipping Checklist

The MAGPIX® overpack contains the following items:

TABLE 1. Shipping Checklist

	Item	Qty	Part Number
	MAGPIX® Instrument	1	55-00022-00-002
	PC	1	64-10084-00-001
	Monitor	1	64-10077-00-001
	All-in-One Monitor Stand	1	64-10050-00-001
	Drive Fluid 2-pack	1	40-50014
	Additional Waste Bottle	1	CN-0261-01
	Sample Probe Needle	2	CN-0221-01
	Power Cord	1	CN-PXXX-01*
	USB Cable	1	CN-0271-01
	Side Access Door Tool	1	CN-0264-01
	Sample Probe Height Adjustment Kit	1	CN-0263-01
	Off-plate Reagent Block	1	CN-0260-01
	xPONENT® 4.2 Software for MAGPIX® (DVD)	1	CN-SWXX-XX
	Installing MAGPIX®	1	89-30000-00-236
	xPONENT® for MAGPIX® Quick Guide	1	89-30000-00-232
	MAGPIX® Hardware Installation and User Manual (CD)	1	CN-M081-01
	xPONENT® for MAGPIX® Software User Manual (CD)	1	CN-M079-01
	PC Installation Instructions	1	89-30000-00-263
	96-wellplate Heater Block (optional)	1	CN-0224-01
	Barcode reader (optional)	1	CN-PC03-01

*XXX is a country specific part number. For more information, contact “*Technical Support*”, on page 66.

NOTE: A MAGPIX Calibration Kit and a MAGPIX Performance Verification Kit are shipped separately.

Chapter 4: Technical Overview

This chapter describes the operation, components, subsystems, and technical specifications of MAGPIX®.

How MAGPIX® Operates

MAGPIX® combines a fluidics system, a mechanical system, an electronic system and an optical system with magnetic microspheres and complex computer analysis to perform multiplex assays.

The mechanical system begins the process. An operator places a 96-well microtiter plate on the plate carrier, which transports the plate into the instrument. The carrier moves along the y-axis, to allow the sample probe access to each column of the microtiter plate. The sample probe assembly moves along the x and z axes, allowing it to access each row of the microtiter plate. Between the y-axis movement of the carrier and the x-axis movement of the sample probe, all wells of the microtiter plate are accessible.

The fluidics system handles the acquisition and transportation of the sample. The sample probe descends into each well, drawing a sample for testing and drawing Drive Fluid from the Drive Fluid container. The sample moves through the fluid tubing to the optics module, transported by the Drive Fluid.

In the optics module, a magnet holds the magnetic microspheres in place while first a red (classification) LED and then a green (reporter) LED illuminate them. They are imaged during each illumination. After the images are recorded, the magnet withdraws, releasing the microspheres for transport to the waste fluid container and to clear the way for the next sample.

xPONENT® software analyzes the images, the red-illuminated images to classify the microspheres and the green-illuminated images to determine what elements of the sample have bonded to their surfaces. It reports the results to the operator.

FIGURE 34. **MAGPIX® Front and Right Side**

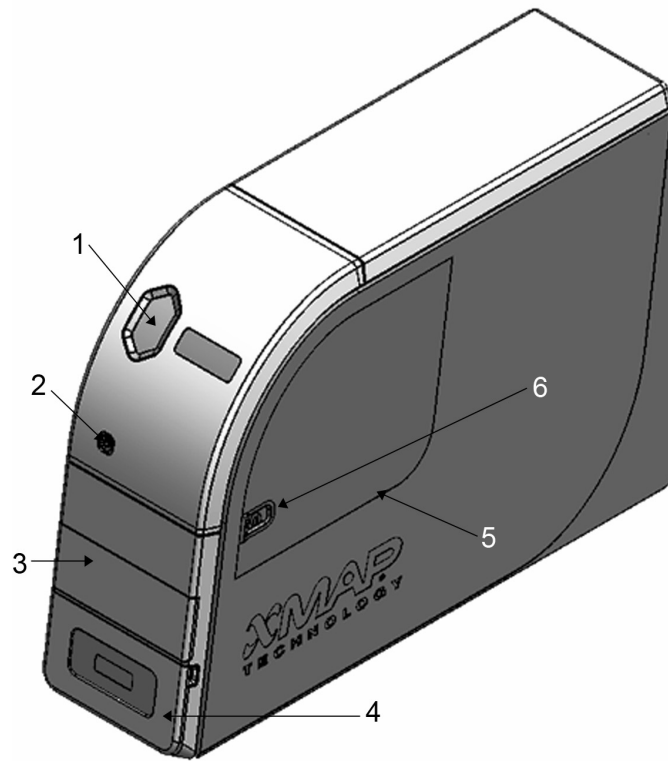

1. Status indicator light	4. Access door for fluid compartment. For a more detailed illustration, see the “Fluid Compartment”, on page 38.
2. Soft on/off switch	5. Side access door
3. Access door for plate carrier	6. Side access door latch

FIGURE 35. **MAGPIX® Back and Left Side**

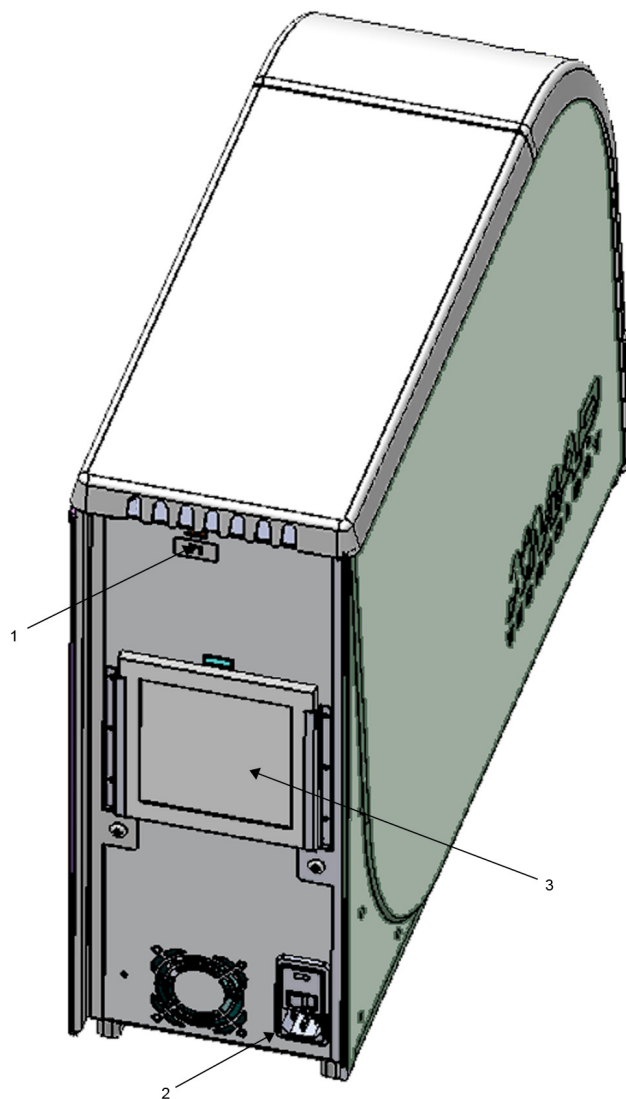

1. Communications port (P1)
2. Power input module
3. Rear air filter

System Components

The following topics describe details of the three components of the Luminex® MAGPIX® system: software, reagents, and hardware.

Software

Luminex® xPONENT® for MAGPIX® software provides complete control of the MAGPIX instrument and performs the analysis. The software requires a dedicated PC. For updated information about the PC or operating system, see *Luminex xPONENT for MAGPIX Software User Manual*.

Under most circumstances, the PC that comes with the MAGPIX system is preloaded with xPONENT for MAGPIX software. Luminex provides a software DVD to use if you need to reinstall the software or need to install it on another computer. If you install the software on another PC, be sure that the PC meets the minimum specifications, including 4.0 GB of RAM and a 2.66 GHz processor. The number of installations you can perform is limited by your license.

The software DVD automatically installs the basic software only. To install the various upgrades, contact Luminex “*Technical Support*”, on page 66. A Technical Support representative can supply you with the correct license number to install upgrades.



CAUTION: If you need to uninstall the software, follow carefully the procedure provided by Luminex “*Technical Support*”, on page 66.

The software is documented in two ways: in online help, which can be accessed from within the application itself, and in PDF form, which is available on the Luminex website and on a CD included with the shipped system.



CAUTION: Luminex recommends that you do not install additional software on the PC that runs xPONENT for MAGPIX, with the exception of Adobe Acrobat. Acrobat is required to view the PDFs and is included on the installation DVD. The operation of xPONENT for MAGPIX has been validated only when xPONENT is the only program running on the dedicated PC.

Hardware

The Luminex® MAGPIX® system includes the following hardware:

- MAGPIX instrument
- Personal computer (PC) and necessary peripherals, including a monitor, keyboard and mouse
- Power cable to connect MAGPIX to power outlet
- USB communication cable to connect MAGPIX to PC
- Two sample probes
- Sample probe height adjustment kit
- Off-plate reagent block
- Additional empty waste fluid container
- Side door access tool
- Barcode reader (optional)
- Heater block (optional)

The hardware is shipped with a quick installation guide, a quick software user guide, a CD containing both the software user manual and the hardware installation and user manual, and a DVD containing the software.

Reagents

Luminex® xMAP® technology requires two kinds of reagents: common laboratory reagents and reagents created especially for Luminex instruments.



CAUTION: Adhere to standard laboratory safety practices when handling hazardous, toxic, or flammable reagents and chemicals. Contact Luminex “*Technical Support*”, on page 66 when in doubt about compatibility of cleaning and decontamination agents or materials.

xMAP® Technology Reagents

- Drive Fluid (unit volume sufficient to run eight 96-well plates)
- MAGPIX® Calibration Kit (to normalize the CL1 and CL2 classification channels and the RP1 reporter channel parameters)

- MAGPIX Performance Verification Kit (to verify system integrity associated with the CL1 and CL2 classification channels, the RP1 reporter channel, and the system fluidics)



CAUTION: Protect MAGPIX calibration and verification reagents from light at all times to avoid photo bleaching of the microspheres.



WARNING: Luminex® Drive Fluid contains ProClin® as a preservative. This can cause allergic reactions in some people. Additional information is available in the Drive Fluid MSDS.

MAGPIX is shipped with a 2-pack of Drive Fluid. A MAGPIX Calibration Kit and a MAGPIX Performance Verification Kit are shipped separately.

Required Laboratory Reagents

- 10% to 20% household bleach solution
- 70% isopropanol or 70% ethanol solution
- 0.1 N NaOH
- Sporidicin® Disinfectant
- Mild detergent
- Distilled water



WARNING: Isopropanol and ethanol are flammable liquids. Keep them away from heat, open flames, and sparks in a well-ventilated area. Remove them from the instrument when they are not in use.

Subsystems

MAGPIX® includes four subsystems: electronic, fluidic, mechanical and optical.

Electronic Subsystem

The electronics subsystem provides the power for operation and control of the MAGPIX® system and communication between its parts.

Power Input Module

The power input module contains the input power plug, hard power toggle switch, and fuses. This is the protective earthing point for the MAGPIX® system. The mating power cord connector type is IEC-320-C13. The mating power cord provides electrical power to the instrument when x-axis is connected to an electrical outlet and is the means of disconnection. The power input auto-senses the voltage range.

FIGURE 36. **Power Input Module**

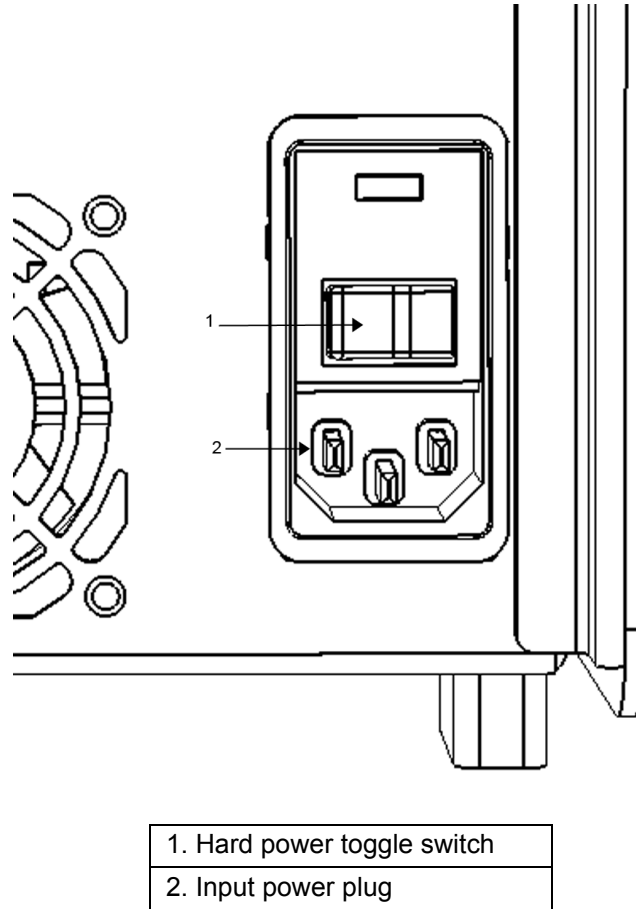

WARNING: Do not obstruct this means of disconnection. Connect only to outlets that contain protective earthing. Before changing a fuse, turn off the instrument and unplug the power cord to avoid any danger of electrical shock.

Communications Port

The communications port connects MAGPIX® to the computer. The communications port is a USB port, labeled P1.

FIGURE 37. **Communications Port**



Printed Circuit Board Assemblies

MAGPIX® requires a series of printed circuit board assemblies (PCBAs), including four major boards: optics control, XY controller, imaging, and processor. These PCBAs are all contained within the same area as the optical system, are not accessible to the user, and require no user maintenance.

Fluidics Subsystem

The fluidics subsystem handles the flow of liquid through MAGPIX®. MAGPIX has two doors that access its fluidics system: a side access door and a front door to the fluid compartment.

Side Compartment and its Components

The side access door, at the upper front of the right side, provides access to the side compartment, which contains the sample probe assembly, the sample valve, the tube between the probe and the sample valve, the filter for the Drive Fluid, and the syringe pump.

The side access door is secured with a latch that requires a door access tool to open.



CAUTION: Keep the side access door closed and latched during normal operation. Unlatch the side access door only to perform maintenance on the user-maintainable parts of the fluidics system.

FIGURE 38. Side Access Door

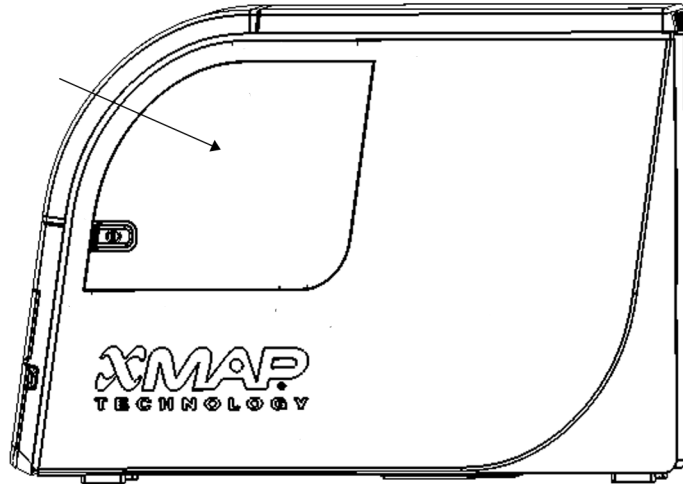
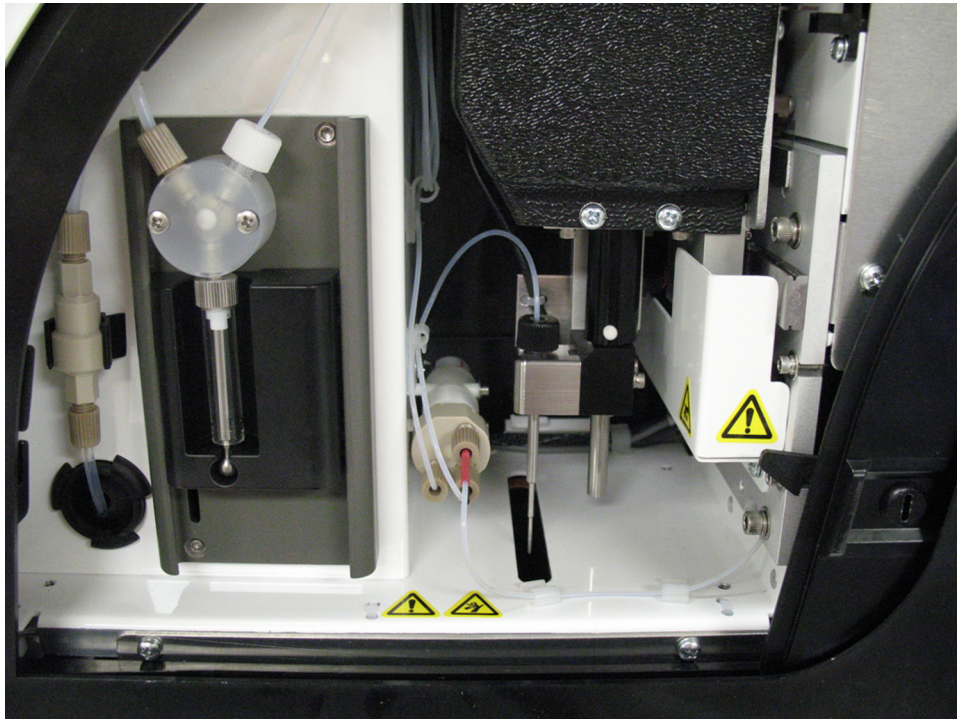

FIGURE 39. Interior of Side Access Door



Sample Probe Assembly

The stainless steel sample probe fits inside a holder. A probe fitting screws into the top of the holder, keeping the probe in place. From the probe, through the fitting, extends a tube that passes through a strain relief and attaches to the sample valve. The sample loop from the syringe pump also enters the sample valve, and a tube extends from it into the optical chamber, carrying the sample mixed with Drive Fluid.

A wheel pulley, covered by a protective shield, moves the probe assembly along the x-axis.

FIGURE 40. Sample Probe Assembly

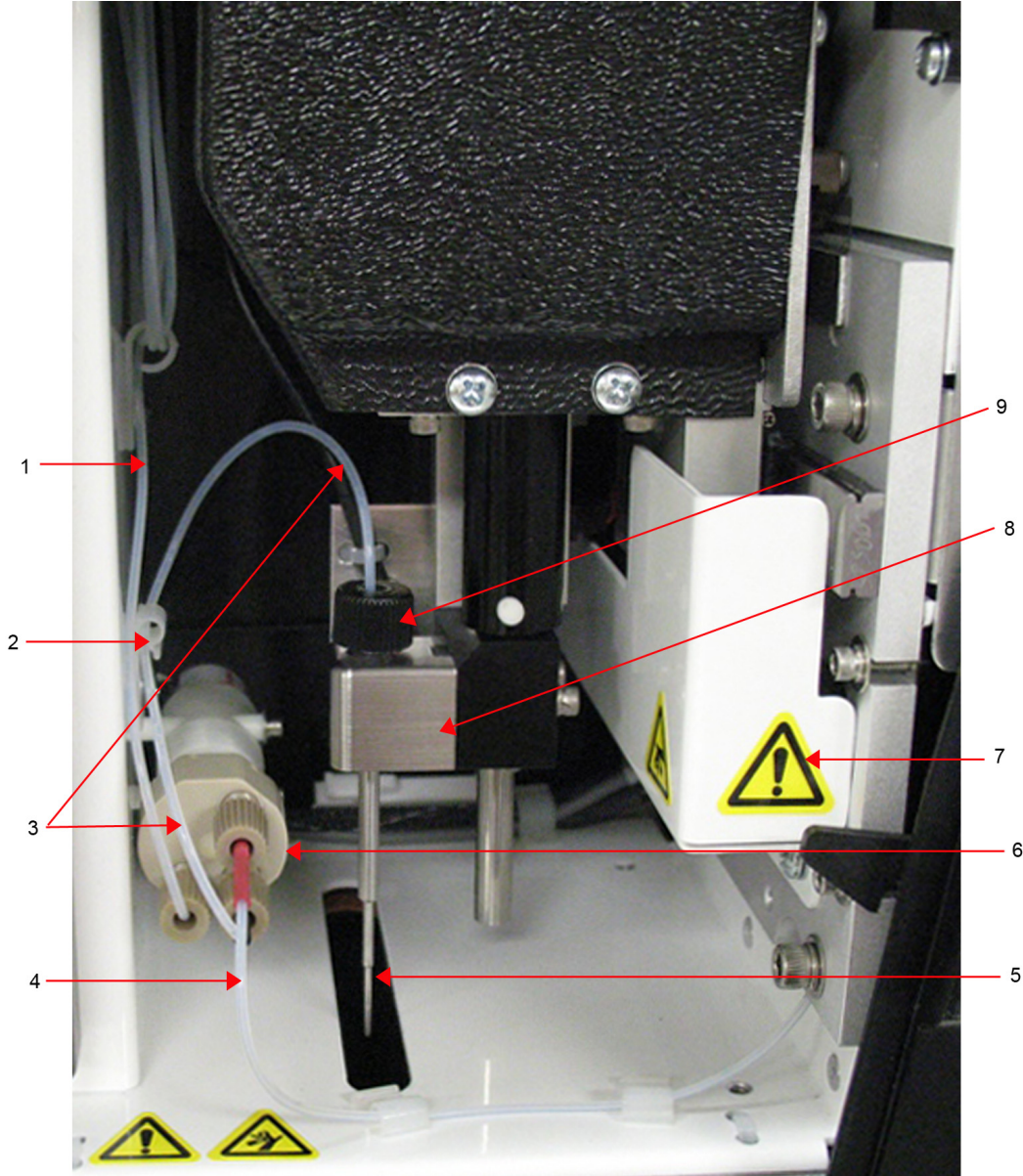

1. Sample Loop	6. Sample valve
2. Strain relief	7. Protective cover on wheel pulley
3. Probe-to-valve tube (coded black)	8. Probe holder
4. Valve-to-optical chamber tube (coded red)	9. Probe fitting
5. Sample probe	



WARNING: Avoid contact with moving parts.



WARNING: Wear appropriate personal protective equipment when handling parts that come into contact with potentially biohazardous samples.

Syringe Pump and Drive Fluid Filter

The syringe pump draws fluid from the Drive Fluid container, in the bottom compartment of the instrument. The fluid first passes through the Drive Fluid filter, which removes particles greater than 35 microns in diameter.

The pumping action results from the up-and-down movement of the plunger guide in its mounting bracket, which moves the plunger up and down in the glass cylinder, drawing Drive Fluid in through the filter and into the valve and forcing the fluid out into the sample loop.

FIGURE 41. Syringe Pump and Drive Fluid Filter

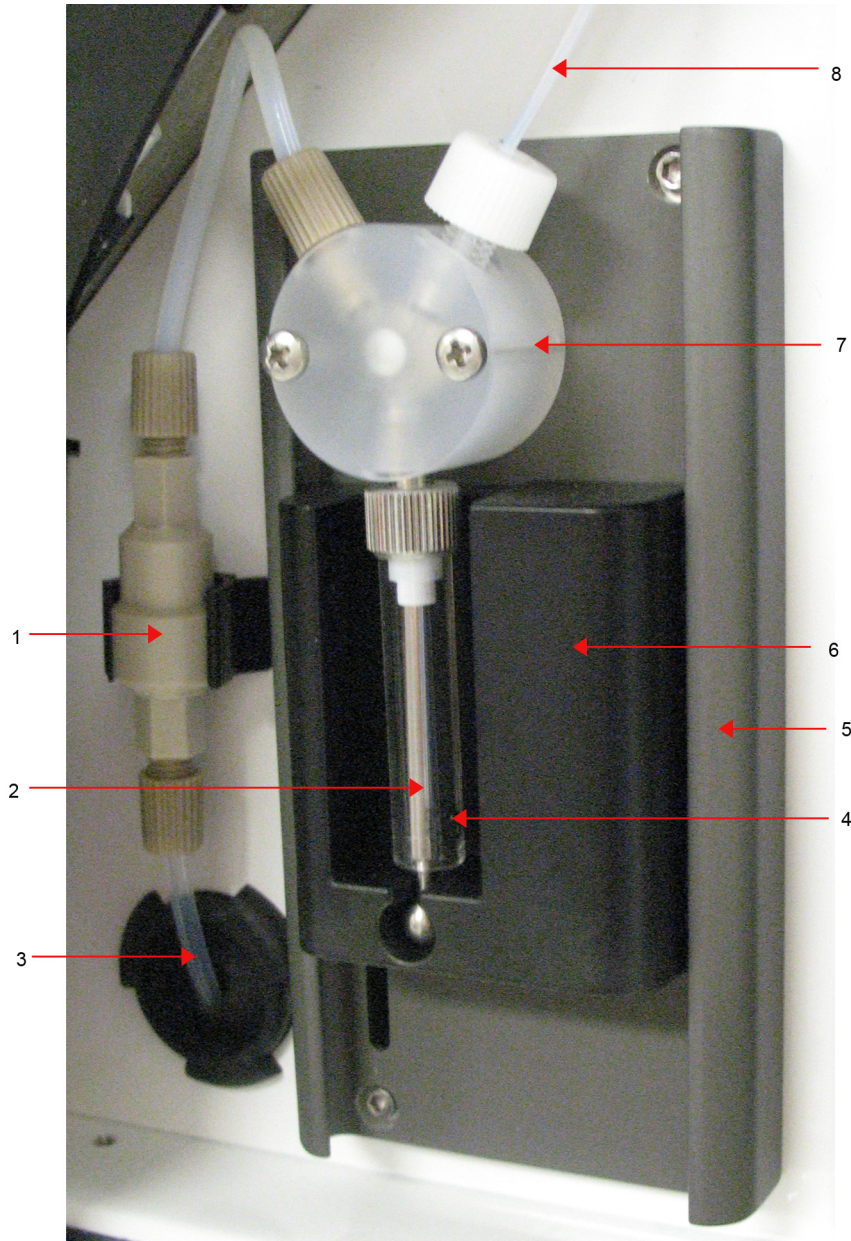

1. Drive Fluid filter	5. Mounting bracket
2. Plunger	6. Plunger guide
3. Tube from Drive Fluid Container	7. Syringe pump valve
4. Glass cylinder	8. Sample loop



WARNING: Avoid contact with moving parts.

Fluid Compartment

At the bottom of the front panel of MAGPIX®, a door folds down to provide access to the fluid compartment. Within that compartment, two trays hold the Drive Fluid and waste fluid containers. Internal sensors monitor the fullness of the waste fluid container and the emptiness of the Drive Fluid container. When either container reaches an unacceptable level, MAGPIX stops. *Luminex® xPONENT® for MAGPIX® Software User Manual* provides instructions for setting up an alert to warn you about unacceptable fluid levels.

FIGURE 42. Door to Fluid Compartment



The Drive Fluid container comes pre-filled and is disposable. The reusable waste fluid container receives waste from the system. The waste and Drive Fluid tubes connect to the waste fluid and Drive Fluid containers using clear tubing.



WARNING: Wear appropriate personal protective equipment when handling parts that come into contact with potentially biohazardous samples. Make certain the waste fluid container is properly vented.

FIGURE 43. Fluid Compartment Interior

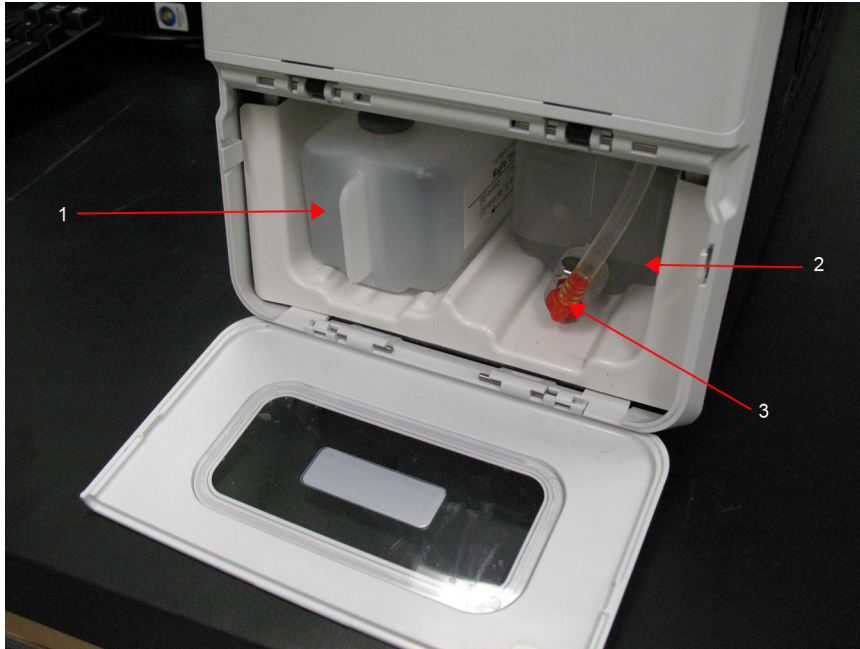

- | |
|--|
| 1. Drive Fluid Container in place |
| 2. Waste fluid container in place |
| 3. Valve attaching waste tubing to waste fluid container |

Mechanical Subsystem

x-Axis and y-Axis Movement

The MAGPIX® mechanical subsystem includes the plate carrier and the assembly that moves the sample probe. The carrier moves along the y-axis, to allow the sample probe access to each row of the microtiter plate. The sample probe assembly moves along the x and z axes, allowing it to access each column of the microtiter plate. Between the y-axis movement of the carrier and the x-axis and z-axis movement of the sample probe, all wells of the microtiter plate are accessible.

FIGURE 44. **MAGPIX® Plate Carrier Assembly**

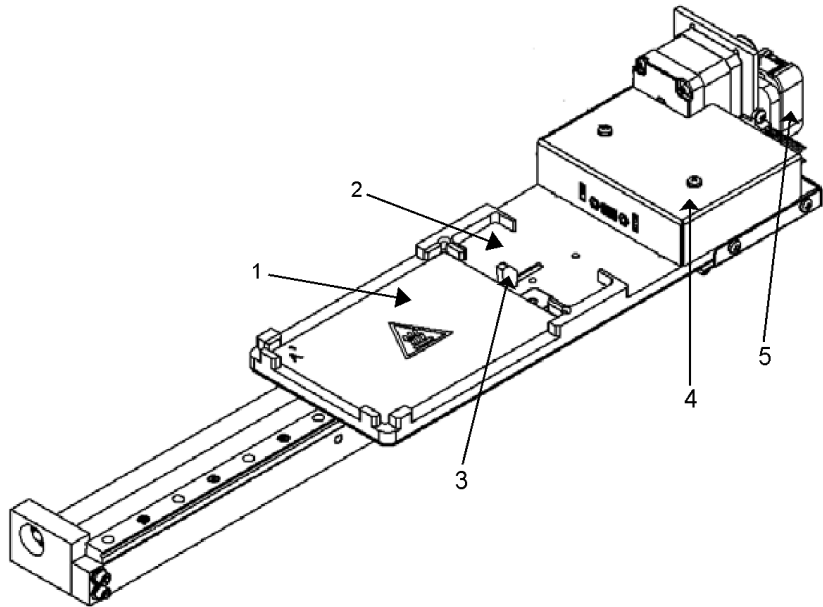

- | |
|---------------------------------|
| 1. Microtiter plate area |
| 2. Off-plate reagent block area |

FIGURE 45. **MAGPIX® Sample Probe Assembly**

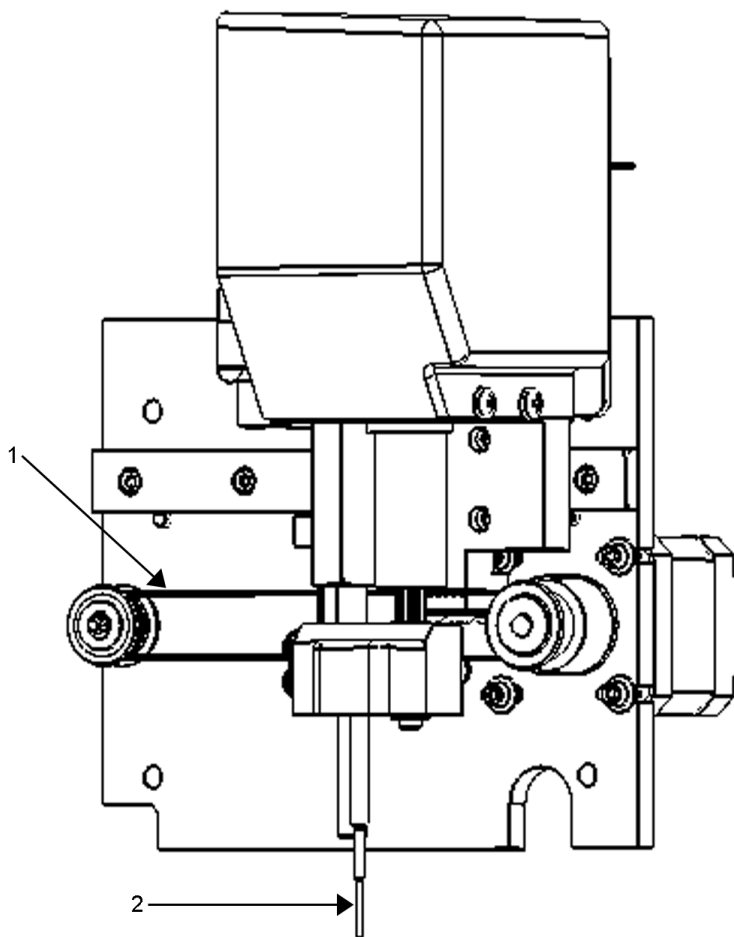

- | |
|---|
| 1. Pulley wheel that moves sample probe assembly along x-axis (cover removed) |
| 2. Sample probe |

Air Filters

MAGPIX® has two air filters, one on the bottom of the instrument and one on the back of the instrument. These filters require periodic cleaning to perform optimally.

The filter on the bottom of MAGPIX can be slid out of its holder toward the front of the instrument. This requires lifting up or tilting the instrument. The filter on the back of MAGPIX can be slid up out of its holder.



CAUTION: Before lifting the instrument, remove all liquid from the off-plate reagent block and remove the fluid containers.

FIGURE 46. Bottom of MAGPIX® showing filter in place in holder

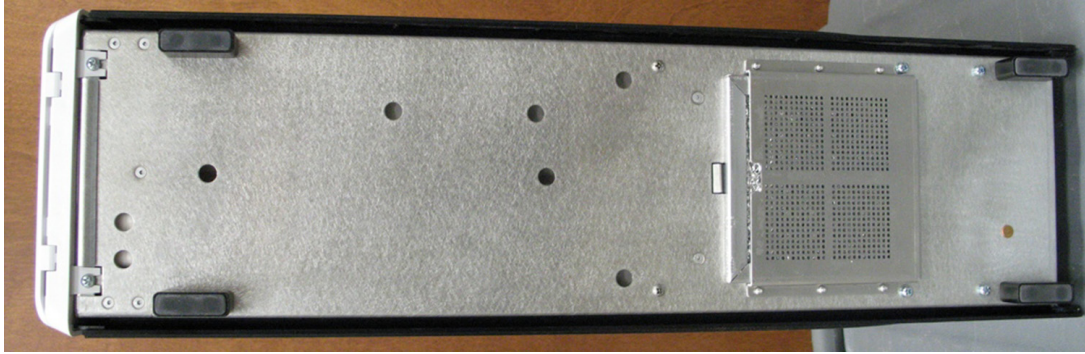
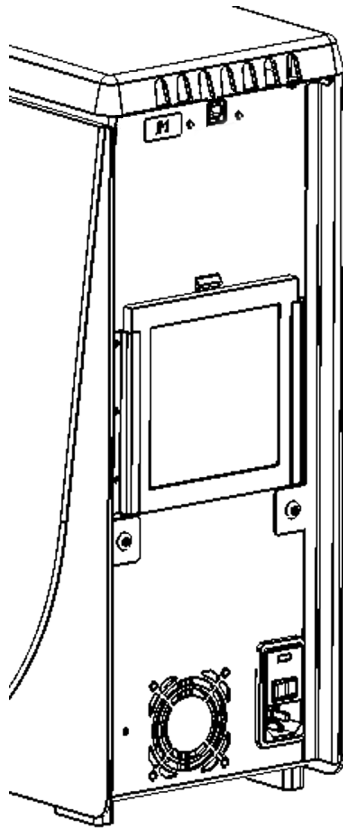

FIGURE 47. Back of MAGPIX® showing filter in place in holder



1

Optical Subsystem

The MagPlex® optical subsystem consists of red and green LED illumination, a CCD-based camera, an imaging chamber, and a magnet to hold the magnetic microspheres in place during the imaging process. The optical subsystem is contained in the same area as the PCBAs. The optical subsystem is not accessible by the user and requires no user maintenance.

Recommended Additional Equipment

Successful operation of the Luminex® MAGPIX® system can require additional equipment.

Uninterruptible Power Supply (UPS) or Surge Protector

Luminex recommends using either an uninterruptible power supply (UPS) or a surge protector to protect your system from power outages. Use a UPS that provides 585 Watts/ 960 VA for at least 60 minutes. Select a surge protector that fits your

requirements with regard to electrical environment, endurance, suppressed voltage rating, and method of protection. The surge protector requires three outlets and a minimum rating of 585 Watts. Either piece of equipment should bear an appropriate safety certification mark for your region, for example, Underwriters Laboratory (UL), Canadian Standards Association (CSA), or Conformité Européenne (CE).

Printer

Use a printer compatible with Microsoft® Windows® XP Pro sp3 or Windows 7, 32-bit.

Barcode Labels

Use Code 128 barcode label type when scanning barcode labels into the system.

Vortex

Use VWR product number 58816-12, with a speed range of 0 rpm to 3200 rpm, or equivalent.

Bath Sonicator

Use Cole-Parmer® product number 08849-00, with an operating frequency of 55 kHz, or equivalent.

System Specifications

General Specifications

- Start-up time: Under 15 minutes, including flushing system lines, system calibration, and system verification
- System verification: 5 minutes
- Shutdown time: Under 15 minutes
- Time to complete one 96-well microtiter plate: Under 1 hour with 50 regions, 2000 microspheres per region per well, counting 50 microspheres in each region, aspirating 30 µL out of a 75 µL sample
- Physical Dimensions: 16.5 cm (6.5") width, 60 cm (23.5") depth, 43 cm (17") height. Additional space required for the monitor/PC stand, keyboard, mouse and barcode scanner does not exceed 64.8 cm (25.5") width x 61 cm (24") depth
- Weight: 40 lbs. (18.0 kg)
- Installation Category II
- Pollution degree 2
- Temperature control: maintains samples using the heater block at a constant temperature from 35°C to 60°C (95°F to 131°F) +/- 1°C of set point.
- Automatic transfer of assay protocols and new reagent information into the system using a large capacity read/write DVD
- Automatic sampling from a 96-well microtiter plate, beginning from any well position
- Automatic real-time analysis
- Analysis of multiple assay protocols per microtiter plate
- Barcode reader entry of sample IDs
- Produces sound pressure levels below 85 dBA

Environmental Conditions

- Indoor laboratory and professional use only
- Operating temperature: 15°C to 35°C (59°F to 95°F)
- Operating relative humidity: 20% to 80%, noncondensing
- Operating altitude: up to 2400 m (7874 ft) above mean sea level
- Shipping temperature: 0°C to 50°C (32°F to 122°F)
- Storage temperature: 10°C to 40°C (50°F to 104°F)

Electronics

- USB 2.0-compatible communications link for fast data transfer
- Input voltage range: either 100 V to 120 V~, 2.0 A 50/60 Hz or 200 V to 240 V~, 1.0 A 50/60 Hz

Optics

- Reporter channel detection: A/D resolution 16 bits
- Reporter detector: CCD, detection bandwidth of 566 nm to 614 nm
- Classification detector: CCD
- Limit of Detection (LOD): For the reporter channel, using a blank microsphere from region 078, ≤ 700 molecules of Phycoerythrin (PE) per microsphere
- Dynamic Range: For the reporter channel, using a microsphere from region 078, ≥ 3.0 decades
- Efficiency: Classification Channels: $\geq 80\%$

Fluidics

- Sample load rate: 20 μL to 500 μL per second
- Sample uptake volume: 20 μL to 200 μL
- Well-to-well carryover: $\leq 4\%$
- Sample uptake accuracy: $\pm 5\%$

Microtiter Plates

- Microtiter plate must be 96-well, not to exceed 1" (2.54 cm) in height, including heater block.
- Microtiter plate must be compatible with the microtiter heater block temperature when the heater block is in use.
- All microtiter plates have standard width (85.5 mm) and length (127.9 mm). Depth varies depending on the type of well. Maximum allowable depth is 1" (2.54 cm). Plates must have minimum 0.06" (1.5 mm) lip height, standard distance from well center to well center (9 mm) and standard distance from A1 center to plate center in both length and width. To be compatible in size with the microtiter heater block, the plate must fit into the heater block so that the top is flush with the heater block.

Microspheres

- Distinguishes 1 to 50 unique MagPlex® Microspheres in a single sample
- Misclassification Rate $\leq 2\%$
- Classification Rate $\geq 80\%$
- Detects and distinguishes surface reporter fluorescence emissions at 590 nm ± 24 nm on the surface of 1 to 50 unique MagPlex Microspheres in a single sample
- Soluble background fluorescence emission at 590 nm ± 24 nm automatically subtracted from fluorescence intensity values

Chapter 5: Operational and Maintenance Procedures

To ensure accurate test results, properly clean and maintain MAGPIX®. Read and follow all instructions in this chapter. To facilitate your maintenance process, print out and use the maintenance logs. See “*Short Term Maintenance - One Week*”, on page 57 for more information.

General Maintenance Precautions

Observe the following general maintenance precautions, which were explained in more detail in the previous chapters:



CAUTION: Personnel who use, maintain, or clean MAGPIX® should be trained in standard laboratory safety practices and should follow those practices when handling the instrument.



WARNING: Samples and waste fluid can contain biohazardous material. Where exposure to biohazardous material, including in an aerosol form, exists, follow appropriate biosafety procedures, use personal protective equipment, and use ventilation devices.



CAUTION: Avoid contact with moving parts. Disconnect the instrument from the power source when the procedure instructs you to do so. Do not remove the cover of MAGPIX. All maintenance can be performed from the outside of the instrument, within the fluid compartment, or within the compartment that is accessible by opening the side access door.

Accessing the Side Compartment

The side compartment of MAGPIX® contains the majority of user-maintainable components. The access door to this compartment must remain latched during operation of the instrument. Opening the access door requires a special tool provided with the MAGPIX system.

FIGURE 48. Side Access Door Latch

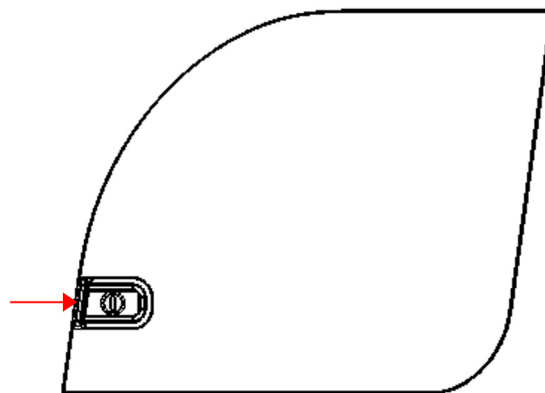

To open the latch:

1. Turn off and unplug MAGPIX.
2. Insert the latch tool into the slot of the latch and turn the tool clockwise.
3. Slide the door to the right.

Daily Procedures

Most of the daily maintenance tasks for MAGPIX® can be performed using available software commands.



For details about performing these commands, refer to the *xPONENT® for MAGPIX Software User Manual* or online help.

Initializing MAGPIX®



Initialize MAGPIX® at the start of each day. Refer to the *MAGPIX User Quick Guide* for instructions for setting up the daily initialization. Initialization requires less than five minutes and includes a quick system self-check.

Verifying MAGPIX®



Perform verification using the xPONENT® for MAGPIX® software. Refer to the *xPONENT for MAGPIX Software User Manual* or online help.

Maintaining Fluids

MAGPIX® has a built-in compartment to hold a single-use disposable Drive Fluid container and a reusable waste fluid container. It comes with two waste fluid containers and a two-pack of Drive Fluid containers. All fluid tubing is contained within the instrument.

Monitor fluid levels daily. Replace the empty Drive Fluid container as needed. If MAGPIX operates with an empty Drive Fluid container, the lack of Drive Fluid can interrupt a sample and prevent further samples from being collected.



CAUTION: Use only xMAP® Drive Fluid. Use of any other Drive Fluid constitutes improper use and can void the warranty provided by Luminex®, its authorized partner, or both.

Empty the waste fluid container whenever the container is full. Use the following guidelines:

- Replace the newly emptied waste fluid container with the second, dry waste fluid container so the moisture remaining in the first waste fluid container does not trigger a “waste bottle full” message.
- Before removing the waste fluid container, make certain all other fittings and tubes are firmly attached to avoid any contamination from dripping waste fluid.

To empty the waste fluid container:

1. Open the fluid compartment at the bottom front of MAGPIX.
2. Disconnect the orange waste fluid line from the waste fluid container.
3. Carefully remove the waste fluid container from its tray.
4. Unscrew the cap on top of the waste fluid container to drain out the fluid.

NOTE: Discard the waste fluid in accord with all local, state, federal, and country-specific biohazard handling regulations.

5. Insert the second, dry waste fluid container in the fluid compartment.

NOTE: Make sure the empty waste fluid bottle is dry or the empty bottle will continue to send a “waste bottle full” message.



WARNING: Waste fluid can contain biohazardous infectious agents. Where exposure to potentially biohazardous materials (including aerosol) exists, follow appropriate biosafety procedures and use personal protective equipment such as gloves, gowns, laboratory coats, face shields (or mask and eye protection), respirators, and ventilation devices.

Shutting Down MAGPIX®

Like initialization, shutdown is a standardized procedure in xPONENT® for MAGPIX® software. The shutdown procedure includes sanitize, clean (with 0.1 N NaOH), and soak routines. Refer to the *xPONENT for MAGPIX Software User Manual* or online help for instructions to perform shutdown.



WARNING: Sodium hydroxide is extremely caustic. If sodium hydroxide comes into contact with skin, it can burn and cause tissue damage without causing pain. Always wear gloves and goggles when working with sodium hydroxide.

Weekly Procedures

Cleaning MAGPIX®

Clean MAGPIX® weekly using a 0.1 N sodium hydroxide (NaOH) solution. Refer to the software manual for instructions for running the **Clean** command.

Cleaning the Sample Probe



WARNING: Avoid contact with moving parts. If a plate is running, use the software to execute **Stop** to avoid the possibility of exposure to moving parts. MAGPIX® must not be performing any operations while you carry out this maintenance procedure.

To clean the sample probe:

1. Execute **STOP** if a plate is running. Refer to the software manual for instructions.
2. Turn off MAGPIX and unplug the power cord.
3. Remove the sample probe.
 - a. Open the side access door of MAGPIX.
 - b. Unscrew the probe fitting on top of the probe completely.
 - c. Grasp the probe gently and push up.
 - d. Lift the probe out of the top of the probe holder.

FIGURE 49. Probe Assembly

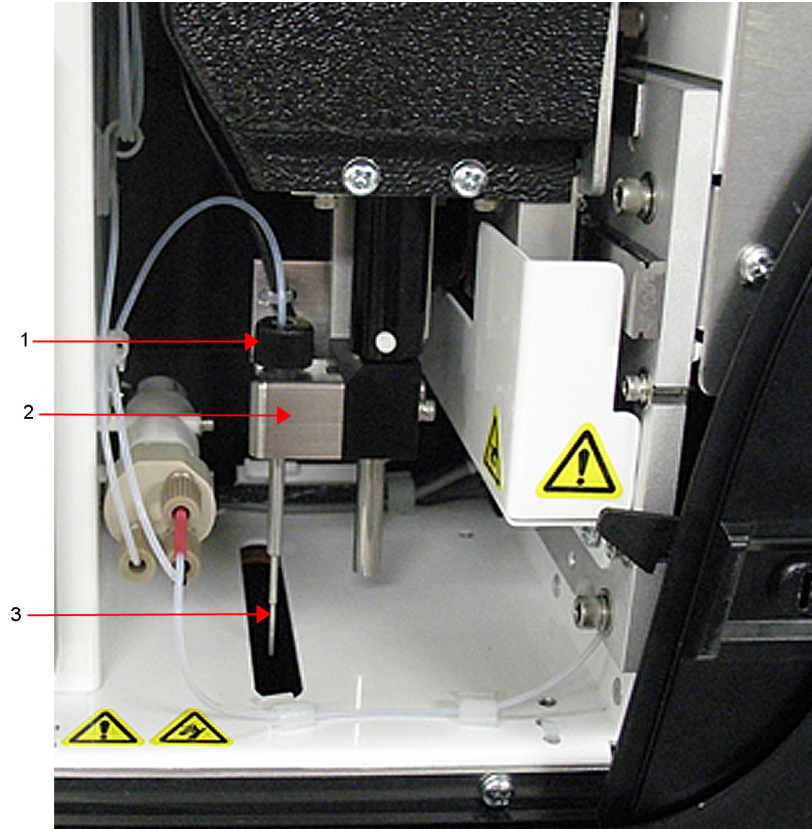

1. Probe fitting - Unscrew and remove
2. Probe holder
3. Probe - Push up gently and lift out of holder

4. Clean the sample probe using a bath sonicator, a 10 mL syringe, or both. If you are using a bath sonicator, place the tip of the sample probe in the bath sonicator for 2 to 5 minutes. If you are using a syringe, force distilled water through the tip of the sample probe to its large end. This dislodges any debris clogging the tip.
5. Replace the sample probe and tightly screw in the probe fitting until it clicks.
6. Use the software to perform an automatic probe height adjustment.

NOTE: Perform an automatic probe height adjustment any time the probe is reinstalled after removal.

Performing a Visual Inspection

Inspect MAGPIX® weekly. Make sure the instrument is idle, so there are no moving parts. Open the MAGPIX side access door and fluid compartment door and visually inspect for leaks, corrosion, and other signs of improper function. Check all visible tubing connections.

Calibrating and Verifying MAGPIX®

Calibration, with a follow-up verification, is another weekly procedure that can be performed using the xPONENT® for MAGPIX® software. Refer to the *MAGPIX User Quick Guide* or the *Luminex® xPONENT® for MAGPIX® Software User Manual* for instructions.

Removing Clogs

If you frequently use MAGPIX® to test concentrated serum or other debris-ridden samples, Luminex recommends that you perform a clog removal routine weekly. Otherwise, you can perform this procedure as needed. See *Luminex® xPONENT® for MAGPIX® Software User Manual* for instructions. Run the **Remove Clog** routine, using sodium hydroxide (0.1 N NaOH) in the Clean reservoir.

To remove clogs:

1. Put sodium hydroxide (0.1 N NaOH) in the Clean reservoir of the off-plate reagent block.
2. Run the **Remove Clog** routine.



WARNING: Sodium hydroxide is extremely caustic. If sodium hydroxide comes into contact with skin, it can burn and cause tissue damage without causing pain. Always wear gloves and goggles when working with sodium hydroxide.

Monthly Procedures

Cleaning the Exterior Surfaces

Clean the exterior surfaces monthly.

To clean exterior surfaces:

1. Turn off MAGPIX® and unplug the power cord.
2. Clean all exterior surfaces with mild detergent, followed by a household bleach solution diluted to 10% to 20%, followed by distilled water.
3. Open the side access door of the instrument.
4. Clean all accessible surfaces with detergent, followed by the household bleach solution (10% to 20%), followed by distilled water.



WARNING: Avoid contact with the tubing and electronic parts of the instrument.

5. Dry any unpainted metal surfaces to prevent corrosion.
6. Plug in the power cord and turn on MAGPIX.

Semi-Annual Procedures

Maintaining Air Filters

MAGPIX® has two air filters, one on the bottom of the instrument and one on the back of the instrument. Every six months, remove these air filters, clean them, and reinstall them.

To clean MAGPIX air filters:

1. Turn off MAGPIX and unplug the power cord.
2. Slide the back filter up out of its holder.
3. Lift MAGPIX and slide the bottom filter out of its holder toward the front of the instrument.



CAUTION: Before removing the bottom air filter, remove both the waste fluid and Drive Fluid containers, the off-plate reagent block, and any microtiter plates in the instrument.

- Clean the filters with a vacuum or with distilled water. Stand the filters upright to air dry.



CAUTION: Filters must be completely dry prior to reinstallation.

- Locate the small incised arrow on the frame of the filter. This indicates air flow. The filter must be installed with the arrow pointing inward.

FIGURE 50. Arrow on Air Filter Frame



- Reinstall filters.
- Plug in the power cord and turn on MAGPIX.

FIGURE 51. Bottom of MAGPIX® Filter holder

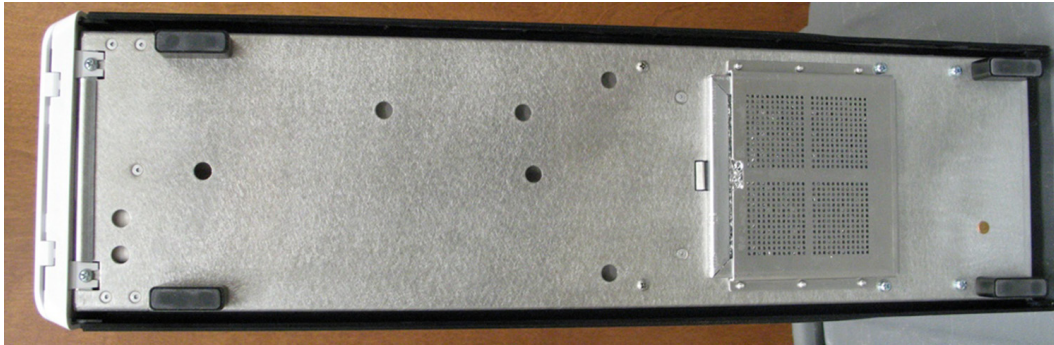
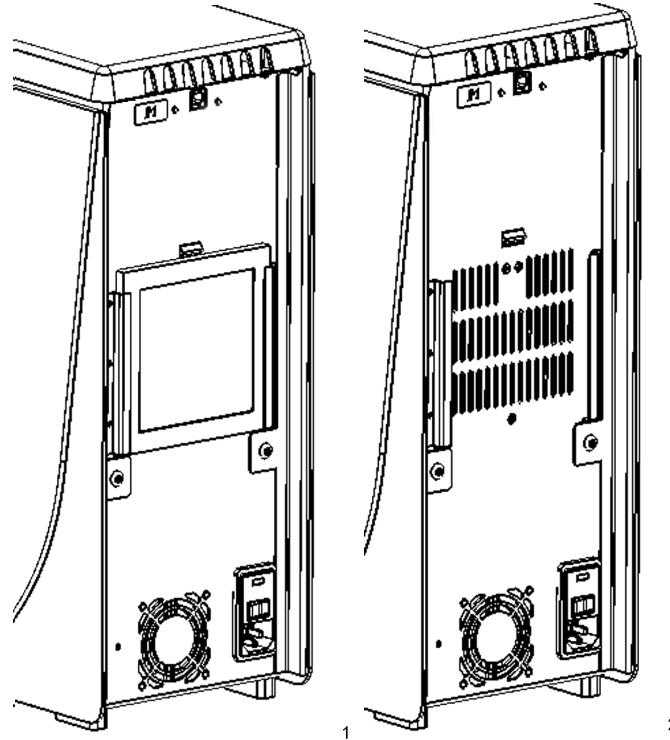

FIGURE 52. Back of MAGPIX® before and after removal of filter



Replacing the Syringe Seal

When you replace a syringe seal, also replace the black O-ring that fits inside it. One package contains four of each.

To replace the syringe seal:

1. Turn off MAGPIX® and unplug the power cord.



WARNING: The plunger guide does NOT deactivate while the seal is being changed; unplugging is necessary to avoid injury.

2. Open the side access door of MAGPIX.
3. Locate the syringe (glass cylinder with a metal rod plunger).
4. Push the plunger guide down. The syringe may fill with clean Drive Fluid.

NOTE: The plunger guide is tight. Be prepared to use some force to push it down.

5. Unscrew the syringe from the top of its housing and carefully remove it.
6. Pull the plunger out of the syringe and dispose of any Drive Fluid.
7. Using a pair of pliers, remove the white plunger seal (at the top of the plunger) and discard it.
8. Place the black O-ring inside the new white plunger seal and press the seal down on the top of the plunger.
9. Return the plunger to the syringe.
10. Screw the syringe back into its housing.

FIGURE 53. The Syringe

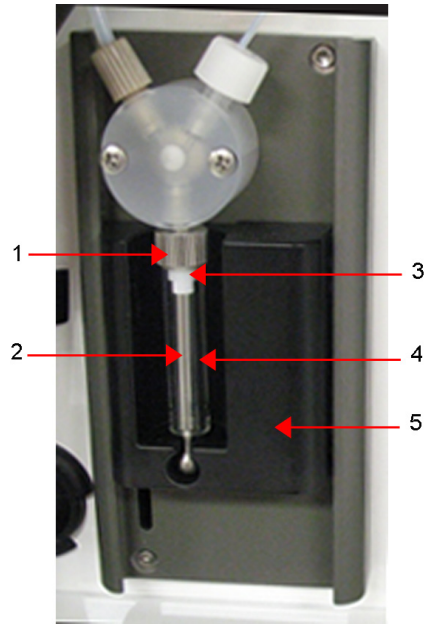

1. Syringe housing
2. Metal rod plunger
3. Syringe seal, containing black O-ring
4. Glass cylinder
5. Plunger guide

11. Return the plunger guide to its original position. The bottom of the plunger fits into the indentation in the plunger guide.
12. Plug in the power cord and turn on MAGPIX.
13. Use the software to run the prime command twice, watching for any leaks in the syringe area.
14. Close the side access door.

Annual Procedures

Replacing the Sample Probe Tube

The tube that connects the sample probe to the valve is subject to wear because of the constant motion of the sample probe. Consequently, maintenance requires replacing it on a yearly basis.

FIGURE 54. **Sample Probe Tube**

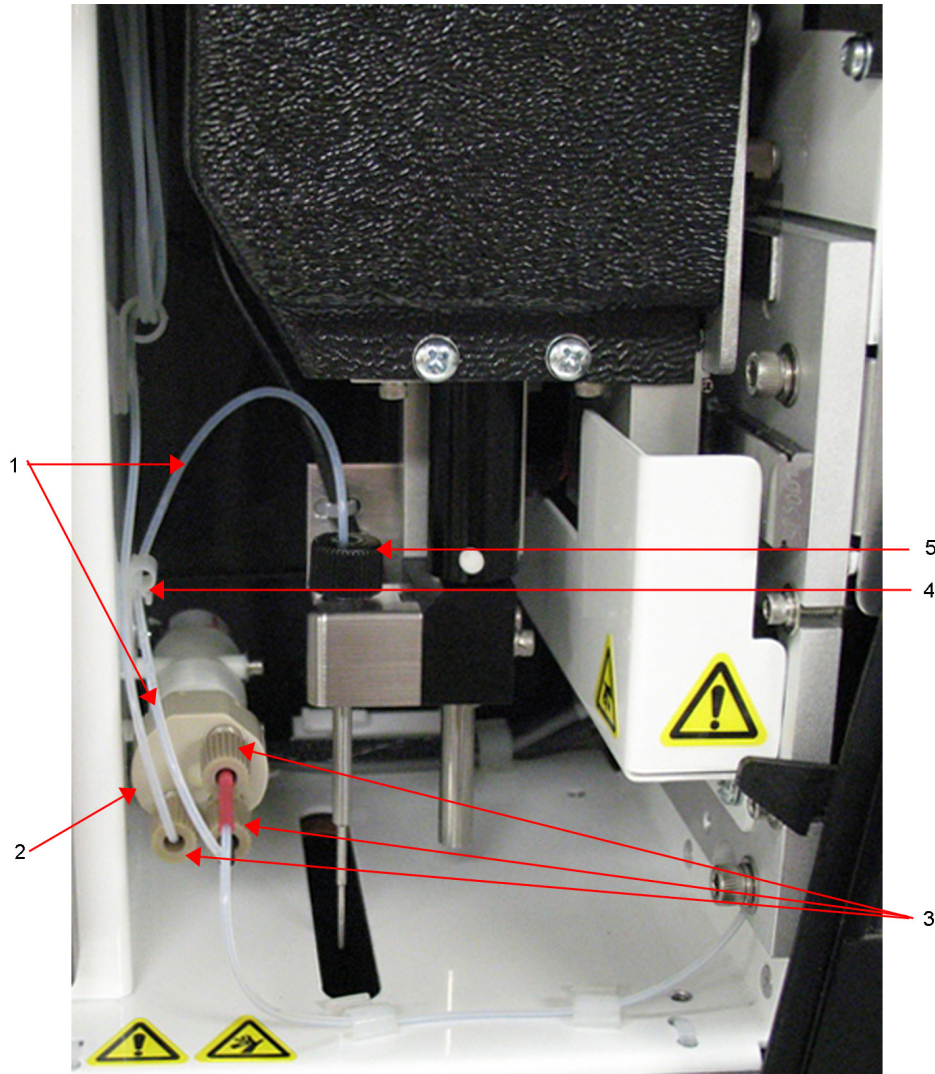

1. Sample probe tube (color-coded black at valve end)
2. Valve
3. 1/4-28 flat-bottom fittings
4. Strain relief
5. Probe fitting

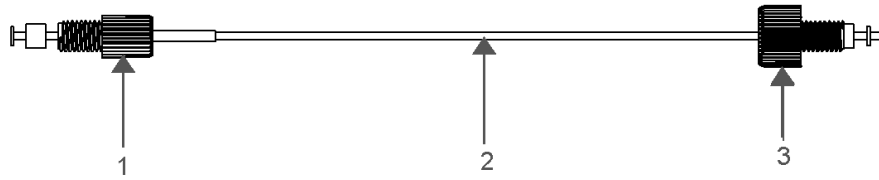
FIGURE 55. **Sample Probe Tube Assembly**

1. 1/4-28 Flat-bottom fitting
2. Tube between probe and valve
3. Probe fitting

To replace the sample probe tube:

1. Turn off MAGPIX® and unplug the power cord.
2. Open the side access door on MAGPIX and locate the probe assembly.
3. Unscrew the probe fitting completely. The sample probe tube is connected to it.
4. Unscrew the 1/4-28 flat-bottom fitting at the valve end of the sample probe tube. The sample probe tube is connected to it. Use pliers to disconnect the 1/4-28 flat-bottom fitting if necessary.
5. Pull the loose tube through the strain relief to remove the tube.
6. Thread the new piece of tube through the strain relief.
7. Screw the 1/4-28 flat-bottom fitting on the end of the new sample probe tube assembly into the valve where you removed the fitting during the step above. Tighten the fitting until it clicks.
8. Screw the probe fitting on the end of the new sample probe tube assembly into the top of the probe assembly where you removed the probe fitting in the step above. Tighten the fitting until it clicks.

Replacing the Drive Fluid Filter

To replace the Drive Fluid filter on MAGPIX®:

1. Turn off MAGPIX and unplug the power cord.
2. Open the side access door on MAGPIX and locate the Drive Fluid filter at the left of the syringe pump.
3. Gently pull the filter from the mounting bracket.
4. Unscrew the tubing from the top and bottom of the filter.
5. Ensure that the Drive Fluid filter orientation (top and bottom) matches the following figure and reattach the tubing to the ends of the new filter. Tighten both fittings until they click.

FIGURE 56. **Drive Fluid Filter**

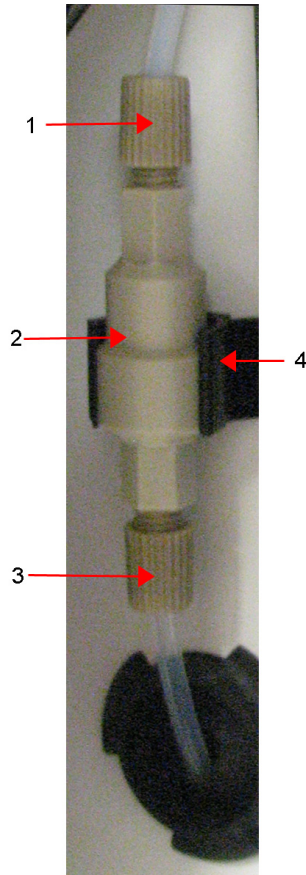

1.	Tube attachments (Unscrew as in step above)
2.	Filter
3.	Tube attachments (Unscrew as in step above)
4.	Mounting bracket

6. Press the new filter into the mounting bracket.
7. Close the side access door.
8. Plug in the power cord and turn on MAGPIX.
9. Use the software to run the **Prime** command twice. Ensure that Drive Fluid is being pulled into the syringe during the prime.

As Needed Maintenance

Replacing Fuses

Periodically, you may need to replace a fuse on MAGPIX®. Use fuses with the following specifications:

F2A, 250 V

The fuse cartridge will accept either 5 mm x 20 mm or 0.25" x 1.25" fuses. Fuses are available from Luminex Corporation. Replacing a fuse requires access to the back of MAGPIX.



DANGER: To avoid serious injury or death by electric shock, turn off MAGPIX and unplug it from the wall before replacing a fuse.

To replace a fuse:

1. Unplug the power cable from the instrument.
2. Use a small, flat blade screwdriver to open the power module door on the lower right corner of the back of the instrument. The door opens downward. Inside is a red cartridge.
3. Use the screwdriver to remove the cartridge.

FIGURE 57. Power Module

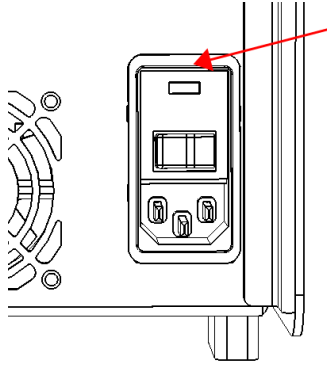

1.	Insertion point for screwdriver blade
----	---------------------------------------

4. Check both of the fuses in the cartridge for damage. A fuse can display physical evidence of damage, for example, broken wire or blackened glass; if it displays no physical evidence, test it for continuity with a voltmeter.
5. Replace any damaged fuse with the correct type of fuse.
6. Replace the cartridge.
7. Shut the module door.
8. Plug in the power cord and turn on MAGPIX.

Maintenance Logs

Reproduce the following forms as necessary and use them to record maintenance information. Fill in the dates in the first line of the table. The first table includes a sufficient number of columns for one week (7 days). The second table includes a sufficient number of columns for monthly maintenance (one task monthly), semi-annual maintenance (two tasks twice yearly), and annual maintenance (two tasks yearly). For each item listed at the left, enter your initials under each date on which you perform the task.

Short Term Maintenance - One Week

Date																	
DAILY MAINTENANCE																	
Initialize with alcohol flush																	
Verify																	
Check fluid levels																	
Shut down with sanitize																	
WEEKLY MAINTENANCE																	
Clean MAGPIX®																	
Clean probe																	
Calibrate and Verify																	
Perform visual inspection																	
Remove clogs (if necessary)																	

Long Term Maintenance - One Year

Date																		
MONTHLY MAINTENANCE																		
Clean exterior surfaces																		
SEMIANNUAL MAINTENANCE																		
Clean air filter																		
Replace syringe seal																		
ANNUAL MAINTENANCE																		
Replace Drive Fluid filter																		
Replace sample probe tube																		

Chapter 6: Troubleshooting Procedures

Troubleshooting procedures help users identify and remedy problems with the instrument.

Overview

To troubleshoot a problem, locate the problem in one of the sections in this chapter, explore the possible causes, and take the described corrective action.

This chapter supplies information about the following topics:

- Power Supply Problems
- Communication Problems
- Clogs
- Fluid Leaks
- Sample Probe Problems
- Calibration Failure
- Verification Failure
- Acquisition Failure
- Carryover Problems
- Bead Detail Irregularities

This chapter does not troubleshoot problems with the PC. For help with PC problems, please contact the “*Technical Support*”, on page 66 department for the manufacturer of your PC.

Power Supply Problems

Power supply problems often involve a blown fuse, faulty electronic component, or disconnected cable.



CAUTION: Whenever you deal with a potential electrical problem, be careful to avoid electrical shocks.

TABLE 2. **Power Supply Problems**

Problem	Possible Cause	Corrective Action
MAGPIX® will not turn on.	The power cord is disconnected.	Plug in the power cord.
	The hard power switch on the back of the instrument is not turned on.	Turn on the switch.
	No voltage is coming from the electrical outlet.	Change to a different outlet. If MAGPIX® is plugged into a surge protector, make certain the surge protector is turned on.
	The power supply is faulty.	Contact “ <i>Technical Support</i> ”, on page 66.
	A fuse has burned out.	See “ <i>Replacing Fuses</i> ”, on page 55.
Fuses continue to open (blow).	Short circuit.	Contact “ <i>Technical Support</i> ”, on page 66.

Communication Problems

Communication problems described in this section involve the links between the data system (PC and software) and MAGPIX®. “Communication” refers to the transfer of data between the PC and MAGPIX, including the current status of the instrument, instrument control, sample acquisition, session uploading, and start, stop, and pause features.

TABLE 3. **Communication Problems**

Problem	Possible Cause	Corrective Action
The PC cannot establish communication with MAGPIX®.	The communication cable is unplugged or plugged into the wrong port.	Plug in or move the communications cable.
	MAGPIX® is not turned on.	Turn off the PC. Turn on MAGPIX® and then turn on the PC.
	Incorrect License	Contact “ <i>Technical Support</i> ”, on page 66.

Clogs

Often, a clog somewhere in MAGPIX® is the cause of a problem with calibration, verification, or data acquisition. To determine whether there is a clog, run performance verification to see if the fluidics function is operating properly. In the event you encounter a problem that is clog related, use the following procedure.

To troubleshoot a possible clog:

1. Clean and adjust the sample probe. See “*Cleaning the Sample Probe*”, on page 47.
2. Perform the procedure for removing clogs. See “*Removing Clogs*”, on page 49.
3. Run calibration and verification.

If this procedure is unsuccessful, call Luminex “*Technical Support*”, on page 66.

Fluid Leaks

There are numerous places in MAGPIX® where fluid can leak. Most leaks can be easily fixed; for the remainder, call “*Technical Support*”, on page 66.

TABLE 4. Fluid Leaks

Problem	Possible Cause	Corrective Action
Fluid is pooled around MAGPIX®.	Fittings, fluid tubes, or components are damaged, loose, or faulty.	Turn off and disconnect the instrument to avoid electrical shock. Check for possible sources of leaking and correct them. If leaking continues, contact “ <i>Technical Support</i> ”, on page 66.
Sample splashing:		
A sample splashes, giving the appearance of a fluid leak.	A sample probe is clogged or partially clogged.	Clean the sample probe. See “ <i>Cleaning the Sample Probe</i> ”, on page 47
	The plate is warped or improperly seated, or plate wells are punctured by the probe.	Replace warped plates; ensure plate is properly centered within plate guides on the plate tray; readjust probe height to ensure wells are not being punctured.
Fluid leaks within the instrument:		
A fluid tube leaks.	The tube is damaged.	If it is the sample probe tube, replace it. “ <i>Replacing the Sample Probe Tube</i> ”, on page 52. Otherwise, contact “ <i>Technical Support</i> ”, on page 66.
The waste bottle leaks.	The waste bottle fitting is loose.	Reset the waste bottle fitting.
The Drive Fluid filter leaks.	Drive Fluid filter fittings are loose.	Hand tighten the Drive Fluid filter fittings.
The sample probe leaks.	The sample probe is clogged.	See “ <i>Clogs</i> ”, on page 59.
	The sample probe fitting is loose.	Tighten the fitting until it clicks.
The sample valve leaks.	The sample valve has one or more loose fittings.	Hand tighten the sample valve fittings.
	The sample valve is faulty.	Contact “ <i>Technical Support</i> ”, on page 66.
The syringe seal leaks.	The seal is worn out or faulty.	Replace the syringe seal. See “ <i>Replacing the Syringe Seal</i> ”, on page 51.
The syringe valve leaks.	The valve is loose or faulty.	Hand-tighten the syringe connection (silver knob) on the syringe valve. Run a Prime command. If leaking continues, contact “ <i>Technical Support</i> ”, on page 66.

Sample Probe Problems

Problems with the sample probe can lead to both fluid leaks and acquisition failure. The following error is associated with sample probe problems:

Error code 2054: Low bead count.

TABLE 5. Sample Probe Problems

Problem	Possible Cause	Corrective Action
The sample probe leaks.		See “ <i>Fluid Leaks</i> ”, on page 60.
The sample arm is stuck in the up or down position.	The sample probe motor connections are loose.	Contact “ <i>Technical Support</i> ”, on page 66.
	The sample probe motor is faulty.	Contact “ <i>Technical Support</i> ”, on page 66.
The sample arm does not go down smoothly.	The microtiter plate is incorrectly seated.	Adjust the microtiter plate.
	The microtiter plate is warped.	Replace the microtiter plate.
	The sample probe is bent.	Remove the sample probe from the instrument and roll it on a flat surface to straighten. If a sample probe has been bent and rolled straight more than once, discard it and replace it with a new sample probe. Perform an automatic sample probe height adjustment using the software.

Calibration Failure

Calibration problems can result from a variety of causes, many of them easily correctable human errors. The following error codes are associated with calibration failure:

- Error code 59: Normalizer has a zero value. Re-calibrate.
- Error code 2054: Insufficient bead count, beads may be out of focus. Self-test may help by re-homing camera.
- Error code 8226: Bubbles sense error.
- Error code 2091: General hardware error was encountered. Self-test to confirm.

TABLE 6. Calibration Failure

Possible Cause	Corrective Action
Possible Calibration Microsphere Causes:	
The calibration microspheres are not fully resuspended	Vortex the calibration vials to resuspend the microspheres.
The wrong lot number or target values were entered in the software.	Correct the lot number and target values in the software.
The calibration microspheres are in the wrong well.	Change the well setting in the software.
There are not enough calibration microspheres in the well.	Add at least six drops of calibration microspheres to the well. For accurate drop volume, hold the vial upside down at a 90 degree angle to the microtiter plate while dispensing them.
You are using the incorrect calibration microspheres.	Use the xMAP® MAGPIX® Calibration Kit.

Possible Cause	Corrective Action
The calibration microsphere lot is expired.	Substitute an unexpired bottle of calibrator microspheres.
The calibration microspheres are photobleached.	Use a different bottle of calibrator microspheres, one which has been protected from light during storage.
Possible Sample Probe Causes:	
The sample probe height is incorrect.	Perform an automatic sample probe height adjustment.
The sample probe is clogged.	See “Clogs”, on page 59.
The probe fitting is loose.	Tighten the probe fitting.
Other Possible Causes:	
There is a partial clog in the instrument.	See “Clogs”, on page 59.
There is air in the instrument. (Error code 8226)	Perform an automatic sample probe height adjustment. Use the software to run a prime command three times, an alcohol flush command twice, then a wash command three times with distilled water.
	Make sure the Drive Fluid coil is not pinched.
The sample valve is faulty.	Contact “ <i>Technical Support</i> ”, on page 66.
There is a problem internal to the instrument. (Error code 2091)	Review the log of calibration reports. Check for dramatic changes in temperature or voltage. If any of these are present, contact “ <i>Technical Support</i> ”, on page 66.
No events are being collected during calibration.	Check the drive and waste fluid levels. Verify that tubing for both containers is tightly connected.
	Check for sample probe problems.

Verification Failure

Like calibration problems, verification problems can have a variety of causes. The following error codes are associated with verification failure:

- Error code 2075 - 2080 R1 - R6: Classification efficiency failure.
- Error code 2081 - 2086: Test failure.

TABLE 7. Verification Failure

Possible Cause	Corrective Action
Possible Verification Microsphere Causes:	
The verification microspheres are not fully suspended.	Vortex the verification vials to resuspend the microspheres.
The wrong lot number or target values were entered in the software.	Correct the lot number and target values in the software.
The instrument verification microspheres are in the wrong well.	Change the well setting in the software.
There are not enough verification microspheres in the well.	Add at least five drops of verification microspheres to the well. For accurate drop volume, hold the vial upside down at a 90 degree angle to the microtiter plate while dispensing them.
You are using the incorrect verification microspheres.	Verify that you are using the xMAP® MAGPIX® Performance Verification Kit.
The verification lot is expired.	Use an unexpired bottle of verification microspheres.

Possible Cause	Corrective Action
The verification microspheres have been diluted.	Substitute undiluted verification microspheres.
The verification microspheres are photobleached.	Use a different bottle of verification microspheres, one which has been protected from light during storage.
Possible Sample Probe Causes:	
The sample probe height is incorrect.	Perform an automatic sample probe height adjustment.
The sample probe is clogged.	See “Clogs”, on page 59.
The sample valve is faulty.	Contact “Technical Support”, on page 66.
Other Possible Causes:	
There is carryover from the calibrators or the previous assay.	See “Carryover Problems”, on page 64.
There is air in the instrument.	Verify the sample probe height. Use the software to run a prime command three times, an alcohol flush command twice, then a wash command three times with distilled water.
	Make sure the Drive Fluid coil is not pinched.
There is a problem internal to the instrument.	Review the log of calibration reports. Check for dramatic changes in temperature or voltage. If any of these are present, contact “Technical Support”, on page 66.

Acquisition Failure

Acquisition failure can result from many of the same causes as calibration and verification failure, in addition to sample and volume problems.

TABLE 8. **Acquisition Failure**

Possible Cause	Corrective Action
Possible xMAP® Microsphere Causes:	
The xMAP® microspheres are not fully suspended.	Gently vortex the microtiter plate or resuspend beads with a multichannel pipette to ensure that the microspheres are present in the solution.
The wrong wells are selected for the xMAP® microspheres.	Change the well setting in the software.
There are too few or too many xMAP® microspheres in the well.	Ensure that there are 2000 to 5000 beads per bead set per well.
The xMAP® microspheres have expired.	Substitute an unexpired bottle of xMAP® microspheres.
The xMAP® microspheres are photo bleached.	Substitute xMAP® microspheres that are not photo bleached.
Possible Sample Probe Causes:	
The sample probe height is incorrect.	Perform an automatic sample probe height adjustment.
The sample probe is clogged.	See “Removing Clogs”, on page 49.
Other Possible Causes:	
The Drive Fluid or waste line is not fully connected.	Disconnect and reconnect the lines.

Possible Cause	Corrective Action
Air is present in the instrument.	Verify the sample probe height. Use the software to run a prime command three times, an alcohol flush command twice, then a wash command three times with distilled water.
	Make sure the Drive Fluid coil is not pinched.
The acquisition volume is set too high.	Set the acquisition volume to at least 25 µL less than the actual volume in your wells. This enables the probe to acquire sample more efficiently with less chance of incorporating air in the sample.
The sample is too concentrated.	Dilute concentrated biological fluids, such as serum or plasma, at least 1:5.

Carryover Problems

Carryover from calibration can interfere with verification; likewise, carryover from an assay can interfere with correct reading of the following assay. Take the following steps to eliminate carryover:

- Begin by performing four rinse cycles.
- If that fails, run the **Clean** command twice using a 0.1N sodium hydroxide solution.
- If running the **Clean** command twice fails, run the **Enhanced Start Up Routine**.

Bead Detail Irregularities

Use these tools to assist in diagnosing instrument vs. kit-related problems:

- MAGPIX® calibrators
- MAGPIX performance verifiers
- assay standards
- assay controls
- error messages

Review the log of calibration reports routinely to detect trends.

Use MAGPIX performance verifiers to check the success of the instrument calibration and to troubleshoot. If there is a problem with kit results, MAGPIX performance verifiers can help determine if the problem is related to the instrument. If calibration and verification are successful, contact the kit manufacturer.

The following table identifies the three possible categories of microsphere dot plots: normal, irregular due to photo bleaching of the microspheres, and irregular due to MAGPIX being out of calibration.

TABLE 9. Types of Dot Plots

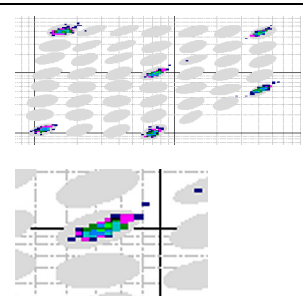
Appearance	Description	Possible Cause	Corrective Action
Normal Bead Grouping			
	MagPlex® verifiers form a tight bead population within the boundaries of the gray region.		

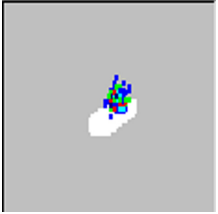
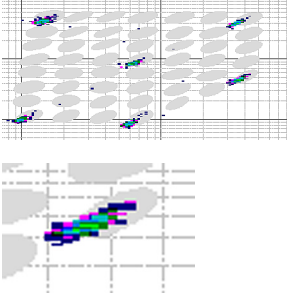
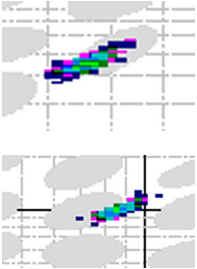
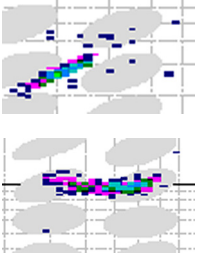
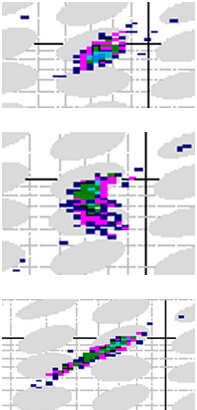
Appearance	Description	Possible Cause	Corrective Action
Irregular Bead Grouping: Photo bleached Microspheres vs. Out-of-Calibration Instrument			
	<p>MagPlex® verifiers are outside of their region (above or to the right).</p>	<p>Instrument is out of calibration.</p>	<p>Recalibrate and verify.</p>
	<p>MagPlex® verifiers are outside of their region (below or to the left).</p>	<p>MagPlex® calibrators are Photo bleached.</p>	<p>Recalibrate with new MagPlex® calibrators and verify.</p>
Irregular Bead Grouping due to Out-of-Calibration Instrument			
	<p>MagPlex® verifiers are anywhere outside of their region.</p>	<p>MAGPIX® is out of calibration.</p>	<p>Recalibrate and verify.</p>
	<p>The dot plot is elongated, horizontally or vertically.</p>		
	<p>MagPlex® beads fail to form a tight population within their regions. The dot plot is wide and possibly extends horizontally, vertically, or diagonally to the left.</p>		

Technical Support

Contact Luminex Technical Support in the U.S. and Canada by calling: 1-877-785-2323

Contact outside of the U.S. and Canada by calling: 512-381-4397

International: + 800-2939-4959

Fax: 512-219-5114

Email: support@luminexcorp.com

Additional information is available on the Luminex website. Search the desired topic or navigate through menus. Also, review the website's FAQ section. Enter <http://www.luminexcorp.com> in your browser's address field.

Appendix A: Storage

If you need to put MAGPIX® in long-term storage - anything longer than a month - or prepare it for use after removing it from long-term storage, use the following procedures.

Storing MAGPIX®

This procedure explains the steps you should take before placing MAGPIX® into long-term storage.

To prepare MAGPIX for storage:

1. Use the software to perform a preparation for storage routine.
2. Remove the sample probe from the instrument and flush it with distilled water from the narrow end out through the larger end.
3. Replace the sample probe in the probe holder and wrap the end of the probe with Parafilm®.
4. Remove the Drive Fluid container and empty the waste fluid container.
5. Eject the plate carrier and remove the microtiter plate and the off-plate reagent block from the plate carrier.

Preparing MAGPIX® for Use After Storage

Follow this procedure before you begin using MAGPIX® after its removal from long-term storage.

To prepare MAGPIX for use after storage:

1. Make sure that the drive fluid container has a sufficient amount of Drive Fluid and that the waste fluid container is empty.
2. Remove the Parafilm® from the end of the sample probe.
3. Turn on MAGPIX and watch for the following indications of correct response:
 - Air blows out of the fans.
 - The syringe inside the side access door of MAGPIX initializes.
4. Turn on the PC and start up the software.
5. Use the software to run a **Revive after Storage** routine.

Appendix B: Shipping

If a serious problem arises with MAGPIX®, it may be necessary to return the MAGPIX to Luminex Corporation for repairs. If Luminex *“Technical Support”*, on page 66 directs you to return MAGPIX®, the Technical Support representative will provide you with all necessary information as well as a Return Material Authorization (RMA) number.



CAUTION: Before the instrument is returned, perform two procedures: Decontaminate the instrument and prepare the instrument for shipping. For the decontamination procedure, see *“Decontamination Procedure”*, on page 7. For instructions to prepare the instrument for shipping, see *“Preparing MAGPIX® for Shipping”*, on page 68.

Preparing MAGPIX® for Shipping

To prepare MAGPIX® for shipping:

1. Disconnect and remove the Drive Fluid container.
2. Remove the off-plate reagent block and any microtiter plates.
3. Perform two **Prime** commands. This should remove fluid from the lines.
4. Empty the waste container.
5. Remove the probe.
6. Reinsert the red shipping plug. The Luminex-provided shipping materials include this.

Shipment Checklist

Complete the following checklist, sign and date it, and return the signed checklist with the MAGPIX®.

1. Remove all specimens from the instrument.
2. Decontaminate the instrument.
3. Prepare the instrument for shipping.

Was there an internal leak in the system? Yes or No

Printed Name _____
Signature _____
Company/Institution _____
Date _____ Instrument Serial No. _____

Appendix C: Part Numbers

Hardware

Product Description	Customer Number
Access Door Tool	CN-0264-01
Fuse 2 AMP 250 V Fast Acting (Qty 1)	CN-0019-01
Sample Probe Needle	CN-0221-01
Heater Block, 96 Wellplate	CN-0224-01
Cable, USB (A to B)	CN-0271-01
Air Filter 4.5 x 4.5	CN-0257-01
Drive Fluid Filter	CN-0258-01
Sample-to-Valve Tubing Assembly	CN-0259-01
Off-Plate Reagent Block	CN-0260-01
Waste Bottle Assembly	CN-0261-01
Syringe, 500 mL Ball End	CN-0262-01
Sample Probe Height Adjustment Kit	CN-0263-01
Barcode Scanner, USB	CN-PC03-01
Cable, Power	CN-PXXX-01*

* XXX is a country specific part number. For more information, contact “*Technical Support*”, on page 66.

Reagents

Product Description	Customer Number
MAGPIX® Calibration Kit	MPX-CAL-K25
MAGPIX® Performance Verification Kit	MPX-PVER-K25
MAGPIX® Drive Fluid, 4-pack	MPXDF-4PK